

English

MODEL

TPUK-BP

topflo[®]
pumps & systems

CE

Operation & Maintenance Manual

PNEUMATIC BATCH CONTROL SYSTEM
PREDETERMINING



Instructions for the installation, start-up, operation, maintenance and repair



Spare parts



STOP

Read this instruction manual carefully before you install and operate this system!

Contents

Page	Section	Sub-section
3	CE Certificate	
4	Introduction	
	Warning symbols	
	Receiving inspection	
	Storage	
5	Mounting	
	Air connections	
	Air preparation	
	Air pressure	
	Health & safety	
	Protection	
	Explosive environments	
6	Principle of operation	
	Key components	Fig.1
7	Stand alone and remote start/stop system configuration	
	Loss of pressure system	
	Essential accessories	
8	Recommended installation – stand alone	Fig.2
9	Recommended installation – remote start/stop	Fig.3
	Required accessories	
10	Set up	
	Setting the predetermining counter	
	Dry test	
11	Wet test	Formula.#1
		Formula.#2
12	Tapflo volume per stroke table	
	System test	
	Siphoning	
13	Operation – stand alone	
	Operation – remote start/stop manual	
	Operation – remote start/stop electrical	
14	Technical Data	Drawing
		Dimensions
		Connections
		Specifications
15	Trouble shooting	
	Routine maintenance	
	Spare parts	
16	Spare parts & warranty	How to order parts
		Returning parts
		Warranty
17	Warranty / return form	
18	Sketch of installation	
19	Notes	

<p>EC DECLARATION OF CONFORMITY</p> <p>CE</p>	
<p>Name and Address of the manufacturer:</p>	<p>Tapflo (UK) Ltd Highcove House Chandlers Ford Ind Est Hampshire SO53 4BU UK</p>
<p>Description of Equipment:</p>	<p>Pneumatic level control system Fully automatic</p>
<p>Model / Type:</p>	<p>TPUK-BP</p>
<p>Directives / Conformity Assessment Procedures:</p>	<p>The Machinery Directive (2006/42/EC) / Non Annex IV Machinery, Self declaration/Technical file</p>
<p>Declaration:</p>	<p>The person signing below declares that the above named equipment fulfils all the relevant provisions of the stated directives.</p>
<p>Place of Declaration</p>	<p>Tapflo (UK) Limited, SO53 4BU, UK</p>
<p>Date:</p>	<p>8/7/2011</p>
<p>Signed:</p>	
<p>Printed Name of Authorised Signatory:</p>	<p>Mr. M. Barnes</p>
<p>Position in Company:</p>	<p>Managing Director</p>

Introduction

Tapflo (UK) pump control systems are designed to offer simple solutions for industrial pumping applications. The systems work in harmony with each pump application utilising similar means of power and methods of construction to give safe, simple and reliable use.

With proper installation, set-up and maintenance Tapflo (UK) systems give efficient and trouble free operation. This manual will familiarize operators with detailed information about installing, operating and maintenance of the system.

Warning symbols

The following warning symbols are present in this instruction manual. The warning information should be observed when either of these symbols is present.



This symbol highlights all safety instructions in this manual where danger to persons may occur. Observe these instructions carefully and proceed with the utmost caution in these situations. Inform all users of all safety instructions. In addition to the instructions in this manual, the general safety and accident prevention regulations must be observed.



This symbol highlights points in the instruction manual of particular importance for compliance with regulations and directives, for correct work flow and the prevention of damage to, or destruction of the system or its associate equipment.

Receiving inspection

Although every precaution is taken when packing and shipping, please carefully check goods on receipt, ensuring all parts listed on the packing note are accounted for. Report any damage or shortages to the delivery company and Tapflo (UK) within 24 hours of receipt.

Storage



If the equipment is to be stored prior to installation, place in a clean dry location ensuring it is not exposed to extreme temperature or humidity, ideally in original packaging to prevent contaminates entering the system.

Mounting



Tapflo (UK) systems will operate properly without being mounted unless otherwise stated. If the system is to be mounted please ensure the surface is suitable for the load detailed in the specifications and appropriate to the system and application.

Air connections



Please ensure all connections observe the specifications of the system, failure to observe this could result in damage to the system and danger to personnel.

Air preparation



All Tapflo (UK) systems are designed to run on clean, dry air, lubrication is not recommended. Maximum pressure is 7 bar (G) unless otherwise stated. An inline filter of 5 micron or finer is recommended to preserve the life of the system.

Air pressure



The maximum pressure specified in the data section of this manual must not be exceeded. Higher pressures can cause damage and may cause injury to personnel.

Health and Safety



Systems must be installed according to local and national safety rules. The system must be suitable for the application. Failure to do so could result in poor performance and a risk to plant and personnel. Consult Tapflo (UK) if in doubt.

Protection



In the interest of health and safety it is essential to wear appropriate PPE when operating and/or working in the vicinity of the application.

Explosive environments



Tapflo (UK) Ltd systems are not certified for use in explosive environments. Consult Tapflo (UK) for further information. Incorrect installation or use may cause injury or death to personnel in the vicinity of the installation!

Principle of operation

Tapflo (UK)'s Pneumatic Batcher is a non-intrusive, fully pneumatic predetermining counter system which records pump strokes as a series of low-pressure pulses from the air exhaust of an AODD pump, stopping the pump once a pre-set number of strokes have been recorded, thus controlling the volume of product dispensed by the pump.

Key components

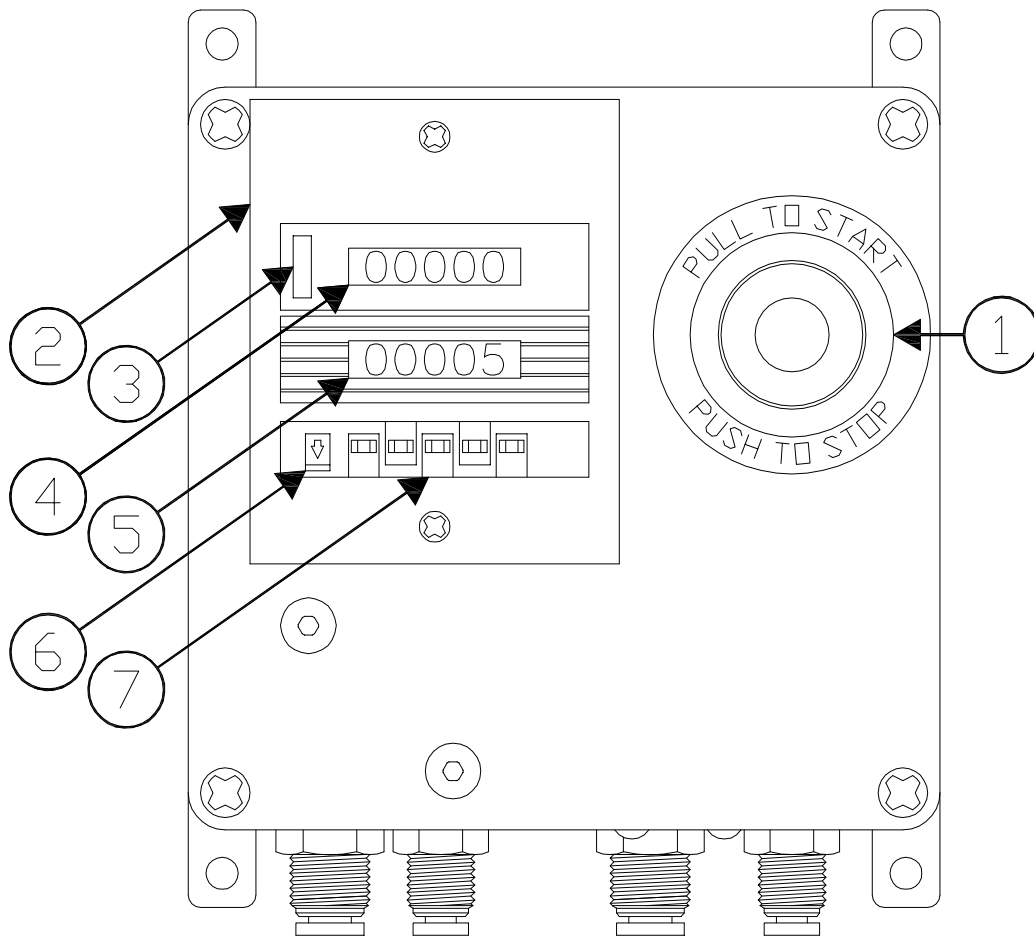

(Fig.1)

Item No.	Description
1	Start/stop push/pull valve and visual indicator
2	Predetermining counter
3	Counter reset button
4	Actual value (pump strokes)
5	Preset value (pump strokes)
6	Preset value adjustment lever
7	Individual digit preset adjustment push buttons (x5)

Stand alone and remote start system configuration

Stand alone

The batcher is positioned within 20 metres of the pump, and controlled using the start/stop push/pull valve (1-fig.1). The predetermining counter is available for the users to adjust.

Remote start/stop

The batcher (1-fig.3) is controlled by either the remote start/stop station (7-fig.3) or directly by using the start/stop push/pull valve (1-fig.1) of the batcher (1-fig.3). It is intended for use where the batcher is located away from the user preventing uncontrolled adjustment of the predetermining counter (2-fig.1), for example the batcher (1-fig.3) is located with the pump (2-fig.3) in a chemical store and the remote start/stop (7-fig.3) is at the dispensing point.

The remote start/stop station (7-fig.3) can also be used to extend the distance between the dispensing point and the pump (2-fig.3), as the remote start/stop station (7-fig.3) can be located up to 20 metres from the batcher (1-fig.3), which can also be 20 metres from the pump (2-fig.3).

The remote start/stop system (7-fig.3) can be offered in either manual or electrical variants allowing the batcher (1-fig.3) to be started from a PLC for example.

Loss of pressure start-up system

The batcher is equipped with a loss of pressure automatic reset system. If the compressed air supply (P) is removed and re-instated the start/stop push/pull valve (1-fig.1) will automatically reset to the 'off' position.

Essential accessories



Items 3 & 4 (Fig.2/3) are essential accessories available from Tapflo (UK). Please consult Tapflo (UK) for further details.

Recommended installation – Stand alone system

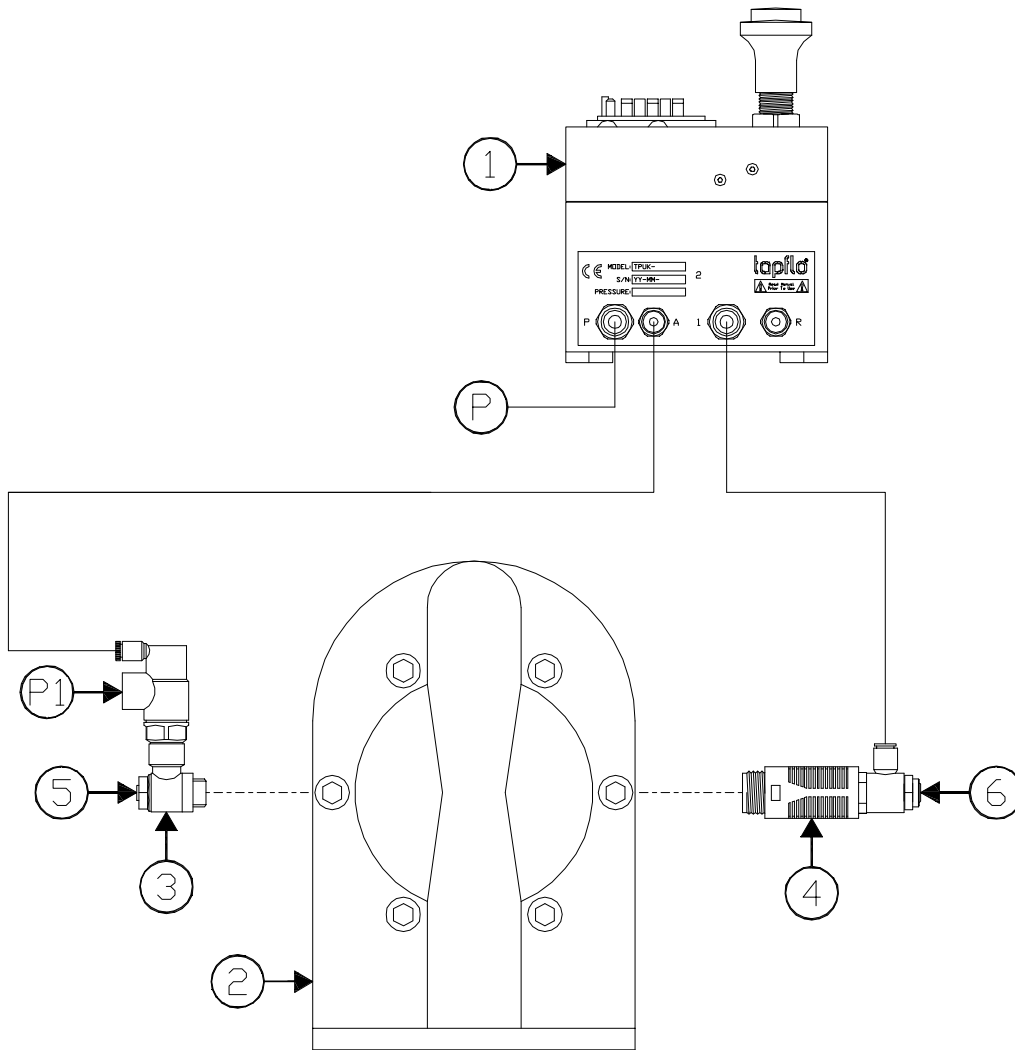

(Fig.2)

Item No.	Description
1	Tapflo (UK) pneumatic predetermining batch control system (TPUK-BP)
2	Pump (for representation purposes only)
3	Combined blocking/needle valve (essential accessory) (Part No. TPUK-B/NV-**, sized to suit pump)
4	Muffer with connection and adjuster (essential accessory) (Part No. TPUK-MU-**, sized to suit pump)
5	Pump speed control adjustment screw
6	Pump stroke sensitivity adjustment screw
P	System air supply connection
P1	Pump compressed air supply port

Recommended installation – With remote start/stop system

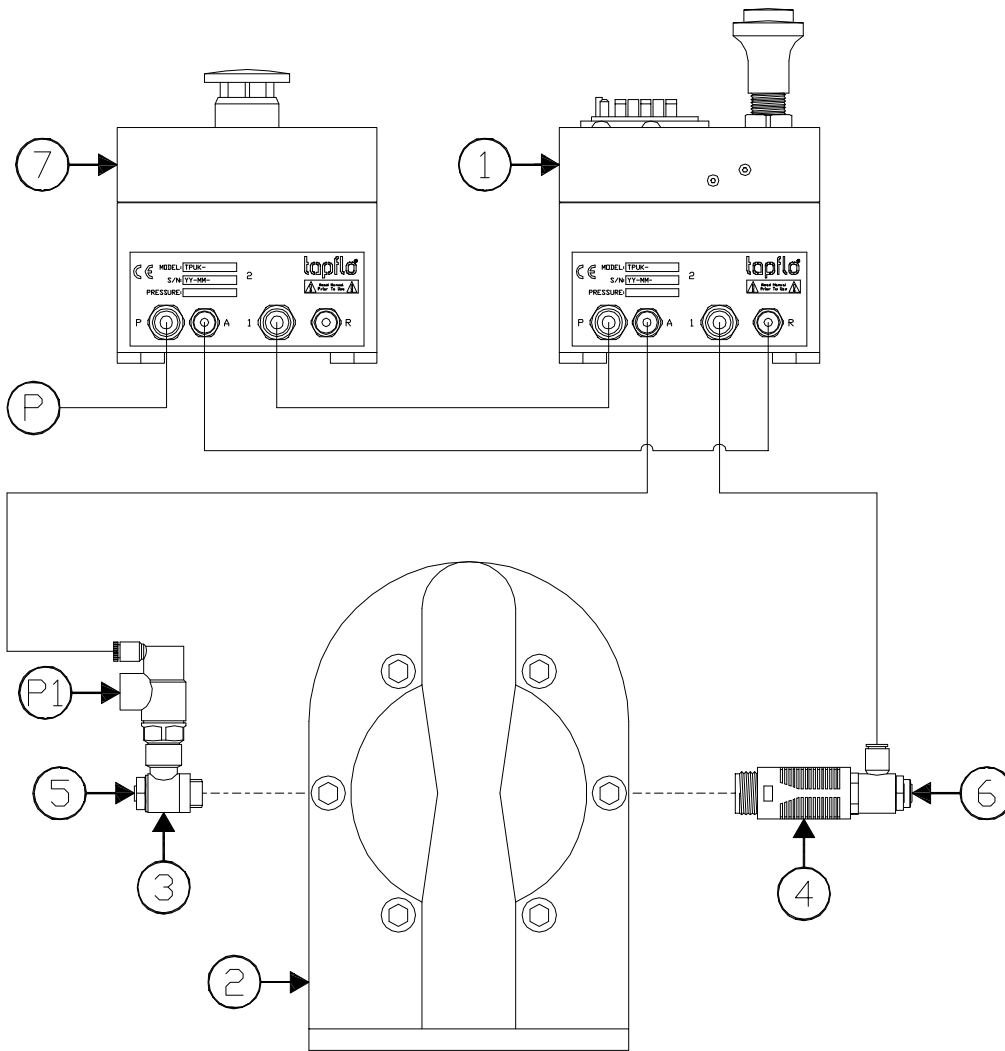

(Fig.3)

Item No.	Description
1	Tapflo (UK) pneumatic predetermining batch control system (TPUK-BP)
2	Pump (for representation purposes only)
3	Combined blocking/needle valve (essential accessory) (Part No. TPUK-B/NV-size, sized to suit pump)
4	Muffler with connection and adjuster (essential accessory) (Part No. TPUK-MU-size, sized to suit pump)
5	Pump speed control adjustment screw
6	Pump stroke sensitivity adjustment screw
7	Tapflo (UK) remote start/stop system (TPUK-SSR or SSE-voltage) (SSR shown for representation purposes only)
P	System air supply connection
P1	Pump compressed air supply port

Set up

Before using the system ensure the following



- The system is configured correctly and has not been modified.
- Make all connections as instructed.
- Set the air pressure.
- Turn the compressed air supply on.
- Check for leaks. (N.B. the system utilizes an 'air bleed' design and discharges a small amount of air during normal use).
- The system is located on a clean, flat surface.

Setting the predetermining counter (2-fig.1)

To program the lower 'preset value' (5-fig.1) to the required number stokes, each digit of the 'predetermining counter' (2-fig.1) can be set independently.

1. Push the white preset value adjustment lever (6-fig.1) as shown by the arrow and hold it.
2. Set the desired value with the corresponding preset push buttons (7-fig.1).
3. Release white preset value adjustment lever (6-fig.1).

Dry test

This sets the sensitivity of the counting circuit and proves the system.

1. Ensure the system is configured as per fig 2/3
2. Using a flat bladed screwdriver turn the "pump speed control adjustment screw" (5-fig.2/3) fully clockwise.
3. Using a flat bladed screwdriver turn the "pump stroke sensitivity adjustment screw" (6-fig.2/3) fully clockwise.
4. Set the predetermining counter (2-fig.1) to 00010 as described in "Setting the predetermining counter (2-fig.1)" section above.
5. Turn 'on' the compressed air supplies P & P1 (fig.2/3)
6. Pull the start/stop push/pull valve (1-fig.1), nothing should happen.
7. Using a flat bladed screwdriver slowly turn the "pump speed control adjustment screw" (5-fig.2/3) counter-clockwise until the pump is running at a controlled rate. The counter should not be counting.
8. Using a flat bladed screwdriver slowly turn the "pump stroke sensitivity adjustment screw" (6-fig.2/3) counter-clockwise until the predetermining counter (2-fig.1) begins to count. After the 10 strokes are recorded the pump will stop.
9. Pull the start/stop push/pull valve (1-fig.1), and the pump should start and the counter should count each stroke cleanly, stopping the pump

- once 10 strokes are recorded.
10. Repeat this test adjusting the settings as per steps 7-9 if necessary.

Wet test



Install the pump into the application, or prepare a test rig to enable the system to pump liquid. The system is best set using the media to be batched, however for safety reasons Tapflo (UK) recommended the system is wet tested with water first, then recalibrated once the whole pump system is installed and tested.

1. Ensure the system is configured as per fig 2/3
2. Set the predetermining counter (2-fig.1) to 00010 as described in “Setting the predetermining counter (2-fig.1)’ section above.
3. Turn on the compressed air supplies P & P1 (fig.2/3)
4. Prime the system by repeatedly running the pump until media is discharged and no air is present.
5. If necessary, using a flat bladed screwdriver slowly adjust the “pump speed control adjustment screw” (5-fig.2/3) until the pump is running at the desired flow rate.
6. Check the predetermining counter (2-fig.1) is counting cleanly, if not using a flat bladed screwdriver slowly turn the “pump stroke sensitivity adjustment screw” (6-fig.2/3) until the predetermining counter (2-fig.1) is recording the stokes cleanly. (N.B. if the pump is running too fast the batcher can struggle to record strokes accurately. If so reduce the pump speed by repeating step 5-6 until the strokes are recorded accurately)
7. Install or position a means of capturing the discharged media such as a suitable container.
8. Pull the start/stop push/pull valve (1-fig.1), and the pump should start and the counter should count each stroke cleanly, stopping the pump after 10 strokes are recorded.
9. Measure the volume of discharged media and using ‘Formula.#1’ work out the displacement per stoke.

$$\text{Formula.\#1} : \frac{\text{Displaced volume (litres)}}{\text{Number of stokes (10)}} = \text{Volume in litres / stroke}$$

10. Repeat steps 7-9 to ensure the accuracy of the above calculation, obtaining an average over several runs.
11. To calculate the number of strokes to give a set volume use ‘Formula.#2’ to work out the number of stokes required for a specific batch volume.

$$\text{Formula.\#2} : \frac{\text{Batch volume (litres)}}{\text{Volume per stroke (litres/stroke)}} = \text{Number of stokes}$$

12. Set the predetermining counter preset value (5-fig.1) to the number of stokes calculated in 'Formula.#2', as described in "Setting the predetermining counter (2-fig.1)" section.
13. Run a test cycle checking the dispensed volume is correct.
Due to compound errors it is often necessary to adjust the number of stokes to give the exact dispensed volume for larger batch sizes.
14. If the correct volume has been dispensed the batcher is calibrated.
15. If the incorrect volume has been dispensed repeat this section.

Tapflo pump volume per stroke table (mL / cu in)

Alternatively the table below can give approximate guidance to the volume per stroke. Using 'Formula.#2' to calculate the estimated number of stokes for a given batch size.

Plastic series		Metal series		Hygienic series	
TR9	13 / 0.80				
TR20	50 / 3.05	T25	70 / 4.27	T30	70 / 4.3
T50	120 / 7.32	T70	87.5 / 5.34	T80	140 / 8.5
T100	280 / 17.1	T120	420 / 25.6	T125	300 / 18.3
T200	1100 / 67.1	T200	933 / 56.9	T225	700 / 42.7
T400	3200 / 195.3	T420	2300 / 140.3	T425	2600 / 158
T800	-	T820	5125 / 312.7		



- The values are for reference only.
- All values were accurate at the time of print.
- All values obtained from latest Tapflo IOM manuals (09/11).
- The values above are based on EPDM diaphragms. Pumps with PTFE diaphragms reduce the volume by approximately 15%

System test



Once the system is fully installed and the media is primed, run some test cycles to confirm the calibration, adjusting the predetermining counter (2-fig.1) to trim the batch size.

Siphoning



If the application has a positive head pressure on the suction of the pump, or the discharge is below the pump/media head there is a chance of siphoning that can cause inconsistent batch sizes. Install a non-return valve in the discharge with a cracking pressure greater than the head pressure to prevent this.

Operation – stand alone

Risk of product splashing or spill!



- Ensure pump discharge is positioned correctly to capture the discharged media.
- Use the correct PPE
- Use a bund if discharging into small containers

To dispense a batch, pull the start/stop push/pull valve (1-fig.1).

- Pump will start and media is dispensed.
- Once the number of stokes recorded equals the number in the 'preset value (pump strokes)' shown on the display (5-fig.1) the pump will stop.
- The dispensed batch will be as per the calibration.

To stop the pump mid-batch, press the start/stop push/pull valve (1-fig.1).

- Pump will stop immediately
- Number of recoded stokes will reset to 00000

Operation – remote start/stop manual

The batcher can be started as per 'Operation – stand alone', but can also be operated via the optional remote start/stop system (TPUK-SSR)

To dispense a batch from the remote start/stop station press the start button

- Batch will be dispensed as per sequence detailed in stand alone system

To stop the pump mid-batch from the remote start/stop station, press the stop button.

- Pump will stop as per sequence detailed in stand alone system

The stop button requires releasing after a mid-batch stop. Twist the stop button to release.

Whilst the stop button of the remote start/stop is pressed the start/stop push/pull valve of the batcher (1-fig.1) is disabled, automatically resetting when the remote start/stop stop button is released.

Operation – remote start/stop electrical

The batcher can be started via an electrical pulse as per the sequence described in 'Operation – stand alone' detailed above (TPUK-SSE-voltage)

Technical data

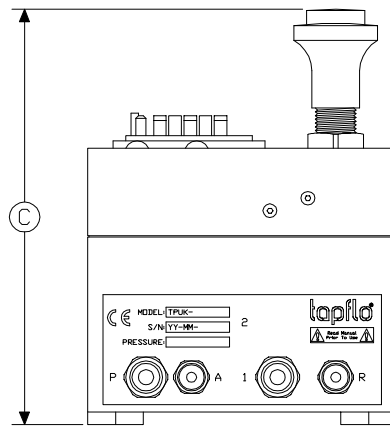
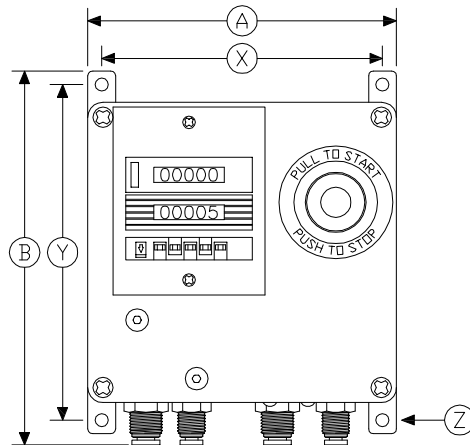

Dimensions

A	122 mm	X	111 mm
B	150 mm	Y	134 mm
C	175 mm MAX	Z	Diameter 5 mm

Connections

Port No.	Description	Connection type
P	Air supply	6mm push fit
A	Pump pilot output	4mm push fit
1	Pump silencer input	6mm push fit
2		
R	Remote start input	4mm push fit

Specifications

Temperature range – Ambient	0°C to +40°C
Air pressure – Min/Max	3-7 BAR (G)
Pilot output flow rate at 6 bar with p=1	120 NI/min (Effective orifice = 2.5mm)
Weight	1100 g

Trouble shooting

Check the system is configured as shown in the recommended configuration then see possible solutions below. If the problem persists consult Tapflo (UK).

Please refer to the pump manual for more detail specific to pump issues.

Symptom	Cause	Remedy
System inoperative	Insufficient air supply.	Check all incoming air supplies are connected and meets minimum requirements.
	Speed control adjusted to closed position.	Adjust the speed control (3-fig.2/3).
	Blocked muffler	Replace and reset muffler (4-fig.2/3)
	Damaged interconnection	Check and repair any blocked or damaged interconnections
	Control system is out of calibration.	Check calibration as detailed in this O&M manual
	Remote start/stop button pressed	Reset as instructed in this manual.
	Pump issue.	See pump O&M manual.
Inconsistent batch sizes	No media	Ensure pump suction is immersed throughout the batch
	Fluctuating air supply	Check all incoming air supplies are connected and meets minimum requirements. Fit regulator.
	Siphoning	Install non-return valve in the discharge line
	Leaking suction connections	Check and remake any damaged or leaking interconnections

Routine maintenance

Routinely check the function and calibration, as normal wear can affect performance. To re-calibrate; follow the instructions in the application specific sections of this manual.

Spare parts



There are no user serviceable parts within the system. The essential accessories are detailed below. Please consult Tapflo (UK) for service.

Quantity	Description	Part number
1	Muffler with connection and adjustment	TPUK-MU- <i>size</i>
1	Combined blocking/needle valve	TPUK-B/NV- <i>size</i>

Spare parts & Warranty

How to order parts

When ordering parts for Tapflo (UK) system, please provide the model number and serial number of the system, position number and quantity of items required.

Returning parts

To return parts to Tapflo (UK) please follow this procedure.



- Consult Tapflo (UK) for shipping instructions
- Cleanse, neutralise and rinse the part making sure the part is completely free from media
- Provide a certificate of decontamination, where appropriate
- Complete the Warranty / Returns form on following page and return articles carefully to prevent any damage during transport

Warranty

Tapflo (UK) warrants products* of its own manufacture will be free from defects in raw material and manufacture under normal use and service period of no more than one year. Tapflo's obligation under this warranty being limited to repair or replacement of its products which shall be returned to Tapflo (UK). Follow the procedures in 'Returning parts' section of this manual. If a part is received defective, report to Tapflo (UK) immediately. Parts returned to our company must have written authorisation from Tapflo (UK). This warranty will not apply to any of our products which shall have been used other than for their intended use.

*Even when products such as diaphragms operate under normal conditions, some parts are subject to wear and may require replacement within the warranty period. Examples of such parts in Tapflo (UK) systems are diaphragms, valve seals, etc'. This warranty will not apply to these parts being subject to wear.

Warranty / return form			
Company			
Address			
Country			
Contact Name			
Telephone		Fax	
E-mail			
Delivery date		Install date	
System Type		Serial No.	
Description of fault			
Media			
Temperature (°C)		Viscosity (cPs)	
Spec. grav. (Kg/m ³)		pH (Value)	
Particle content (%)		Particle size (mm)	
Duty (h/day)		Starts per day (No.)	
Media Pressure (bar)			
Air pressure (bar)		Air quality	
Notes			

Warranty / return form

Sketch of installation

Notes

Whilst every effort has been made to ensure that all the information contained in this document is correct at the time of publication, due to our policy of continuous product improvement, the company reserves its right to change any information contained herein without notice.



Tapflo UK Ltd -
Tapflo House, Victory Close, Chandlers Ford, Hampshire SO53 4BU
t: +44 (0)23 8025 2325 f: +44 (0)23 8026 9016
e: sales@tapflopumps.co.uk w: www.tapflopumps.co.uk

DISTRIBUTOR: