

**Congratulations on your new System Cleaners low-pressure cleaning system
of the type:**



KPV 100 and KPV 150 chemical pump station

In order to obtain detailed knowledge of your system, see page:

1. General

Introduction.....	2
Liability provisions.....	2
Warranty conditions.....	2
General information.....	2
Protection against frost.....	2
Important.....	2
Storage.....	2
Declaration of conformity.....	2

2. Safety

Safety during operation.....	3
Safety precautions.....	3
Proper use.....	3
Safety instructions during operation.....	3-4
Disposal.....	4
Labelling.....	4

3. Spare parts

Spare parts, KPV 100.....	5
Parts list, KPV 100.....	6-8
Spare parts, KPV 150.....	9
Parts list, KPV 150.....	10-12
Electronic control unit.....	13-15
Components.....	15

4. Operation

Quick guide.....	16
------------------	----

5. Maintenance

Maintenance.....	17-18
Recommended spare parts.....	19

6. Adjustment

Adjustment.....	20
-----------------	----

7. Troubleshooting

Troubleshooting.....	21-22
----------------------	-------

8. Installation

Installation.....	23
-------------------	----

9. Key drawing

Key drawing, KPV 100.....	24
Key drawing, KPV 150.....	25

10. Starting up the system

Start.....	26
Stop.....	27

11. Electrical installation

Wiring diagram.....	28
Siemens LOGO! module.....	29-30

12. Technical specifications

Technical specifications.....	31
-------------------------------	----

1. General

1.0 Introduction

System Cleaners A/S congratulates you on the purchase of your System Cleaners low-pressure cleaning system, which has been developed for professional cleaning purposes.

The process of development has focused on the system being simple, reliable and robust. It is designed to comply with the strict hygiene requirements that are in force today, and configured for optimum levels of operation and safety.

The cleaning system is manufactured from the best corrosion-proof materials and assembled according to modern production principles.

In order to achieve the best possible utilisation of the system, the instruction manual should be read carefully before use.

1.1 Liability provisions

Each user must handle and use the system in a responsible manner. It is therefore of great importance that this instruction manual is available to the sanitation employee concerned at all times.

1.2 Warranty conditions

For a period of 24 months from the date of delivery, your dealer will honour a warranty on parts that do not function properly due to material defects or manufacturing faults. The warranty does not cover wearing parts (described in the section on spare parts). The warranty will cover replacement or repair of the defective part. Costs with regard to dismantling, forwarding and reassembly are defrayed by the purchaser. Any return shipments from System Cleaners A/S following completed repairs are defrayed by System Cleaners A/S. The defective parts remain the property of System Cleaners A/S.

Claims that may be made for legal reasons, ordinary wear and tear, as well as damage to parts that can be attributed to negligent or improper handling are not covered by the warranty.

The warranty will be void if the system has been exposed to frost.

The warranty will also be void if modifications or repairs have been carried out by unauthorised personnel. Warranty claims will only be accepted if they are reported to System Cleaners A/S immediately after damage has been discovered. The warranty is terminated if there is a change of ownership of the machine.

System Cleaners A/S and its dealers cannot be held liable for personal injury, damage to equipment, loss of earnings, including production losses, losses to stock or similar that may have arisen as a result of defects or delayed delivery of the sold product, irrespective of the cause, including manufacturing faults or material defects. In addition, please refer to our general terms and conditions of sales and delivery.

1.3 General information

Manufacturing tolerances on nozzles, pressure gauges and pumps can in certain cases lead to minor deviations from specified values. This has, however, no impact on the cleaning efficiency.

1.4 Protection against frost

The machine must not be exposed to frost unless it has been emptied of water (frost protected). Even brief periods of exposure to frost may cause damage to the equipment.



Important!

This symbol refers to safety and elements of danger. Disregarding these references can result in injury or damage to persons or property.

1.5 Storage

You are requested to keep this instruction manual at a location where it will be available at all times, and it should be submitted to the person who is responsible for this product. In the event that the instruction manual is lost, you are welcome to order a new one from your dealer.

1.6 Future-proofing

Should you desire functions on your system that have not been included from the start, this can be done by purchasing and installing one of our kits.

1.7 Declaration of conformity

We declare that this product is in conformity with the following directives:

- 2006/42/EC Directive on Machinery
- 2014/35/EU Low Voltage Directive
- 2014/30/EU EMC Directive

Per Kjøller
Development Manager

2. Safety

2.0 Safety during operation



- **It is recommended that suitable working clothes be worn, e.g. as protection against 70°C hot water. Always use protective goggles, respiratory protective equipment and rubber gloves.**
- The system should not be started up before the operators that are to use the system have been instructed in the correct use, adjustment and maintenance hereof.
- Never direct the water jet at other persons.
- Only use original System Cleaners hoses and couplings.
- Check that couplings "lock" when hoses and nozzles are fitted. If possible, practise this procedure before operation.
- Always relieve the pressure in the rinsing hose by opening the low-pressure valve/gun (AFTER the water supply has been shut off) before dismantling the couplings and removing the hose.
- During operation of the system, ensure that the low-pressure gun/valve is closed before releasing the handle.
- When the low-pressure gun/valve is opened, the water jet will result in a certain amount of counter-pressure. Therefore make sure that you hold the handle firmly and have a firm foothold.
- It is recommended that non-slip footwear be worn since the floor can sometimes be slippery due to the presence of water and foam.
- When using detergents, it should be remembered that certain types of detergent can produce toxic gases when mixed. Further information can be obtained from the chemical supplier.
- The noise level of the machine itself is less than 70 dB(A). However, when rinsing, the operator will be exposed to the noise of the jet of water hitting the floor, walls, and equipment. When rinsing stainless steel surfaces with a 25/40 System rinsing nozzle (25 bar), a noise level of 88 dB(A) can be registered.
- The actual noise level depends on factors such as the size and layout of the room, the machines to be cleaned, etc., as well as the type of nozzle used. In general, the noise increases with greater quantities of water and smaller spray angles. In any event, hearing protection should be worn when rinsing.
- The hand-arm vibration level, measured on the low-pressure gun fitted with a rotating nozzle, is less than 2.5 m/s² (8.2 ft/s²).
- Never direct the water jet at electrical equipment.
- Avoid water in electrical plugs or sockets.
- Never insert or remove a plug from an electrical socket unless the power has been switched off.

2.1 Safety precautions

The design of the system complies with generally accepted technical regulations and provisions concerning the working environment and accident prevention. Despite this, risks can occur during use that can lead to physical inconvenience for the user or a third party or have an impact on the machine or other equipment.

The system must therefore be in prime technical condition before use and may only be used in accordance with its specified purpose and with strict observance of the safety requirements and operating instructions. In particular, malfunctions and irregularities that can affect safety must be remedied immediately.

2.2 Proper use

System Cleaners low-pressure cleaning systems are exclusively designed to be used for:

- rinsing with water
- application of foam or detergent within the specified operating conditions.

All other forms of application or use not within the scope of the above are considered to be improper and inconsistent with the requirements and regulations, and may lead to hazardous situations. System Cleaners A/S cannot be held liable for consequential damage resulting from improper use of the equipment.

Proper use includes the following:

- The instructions, regulations and recommendations concerning the system stated in the instruction manual
- Observance of the specified inspection and maintenance intervals
- Correct maintenance of good operating condition of the system
- Observance of the specified environmental and operating conditions

Proper use also includes observance of all information that is stated in this instruction manual. This applies in particular to the specified safety instructions.

2.3 Safety instructions during operation

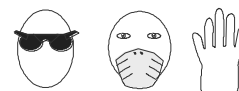

- **It is recommended that suitable working clothes be worn. For protection against certain types of detergents, always use protective goggles, respiratory protective equipment and rubber gloves.**
- It is recommended that non-slip footwear be worn since the floor can be slippery due to the presence of water and foam.
- This system may only be operated, maintained and - not least - repaired by persons who are familiar with the system and properly trained to carry out the job concerned.
- It is the customer's responsibility that these installation and operating instructions are supplemented by in-house instructions concerning inspection and reporting, industrial management, personnel training, etc.
- Do not carry out any work if you are unsure of the consequences or are insufficiently skilled to carry it out. If in doubt, you should contact your superior or your agent in advance.

2. Safety, continued

2.3 Safety instructions during operation, contd.

- Never direct the water jet at other persons.
- Never direct the water jet at electrical installations.
- Check that couplings "lock" when hoses and nozzles are fitted. If possible, practise this procedure before operation. Always relieve the pressure in the rinsing hose by opening the low-pressure gun/valve (AFTER the water supply has been shut off) before dismantling the couplings and removing the hose.
- During operation of the system, ensure that the low-pressure gun/valve is closed before releasing the handle.
- When the low-pressure gun/valve is opened, the water jet will result in a certain amount of counter-pressure. Therefore make sure that you hold the handle firmly and have a firm foothold.



- Before removing the cabinet, the power supply MUST be switched off.
- Safety precautions and safety devices must comply with national regulations applicable at any time (e.g. Power current regulations, EN 60204 or EN 50178).
- Requisite safety precaution: earthing of unit.
- Requisite safety device: Overload protection (fuses)
- Internally, protection corresponds to IP 55. On a number of components hazardous voltages can occur. During operation the cabinet must always be closed.
- Never insert or remove a plug from an electrical socket unless the power has been switched off.



System Cleaners low-pressure systems may only be used in conjunction with soaps and chemicals that are approved for cleaning within the food or transport industries.

Soaps and chemicals that are classified as highly corrosive, toxic or which pose a health risk to humans or animals may not be used.

The system must not be used together with solvents or volatile liquids that pose a health risk or are inflammable.

In the event that the system is used with non-approved soaps, chemicals or solvents, System Cleaners A/S disclaims all liability.

If in doubt, please contact your soap or chemical supplier and read the supplier manual.

In the event that you use the system with chemicals that require mandatory labelling, or if the water temperature exceeds 50°C, a low-pressure gun with an automatic closing device must be used. In the event that you use the system without a gun with an automatic closing device together with chemicals that require mandatory labelling, or water with a

temperature that exceeds 50°C, System Cleaners A/S disclaims all liability.

2.4 Disposal

Please be aware of the following applicable provisions: the equipment must be disposed of according to its nature and applicable requirements, e.g. electrical scrap, synthetic material, stainless steel, brass, etc.

2.5 Labelling

The system is equipped with a type plate containing technical data. The type plate is located on a fixed part of the system.

3. Spare parts, KPV 100

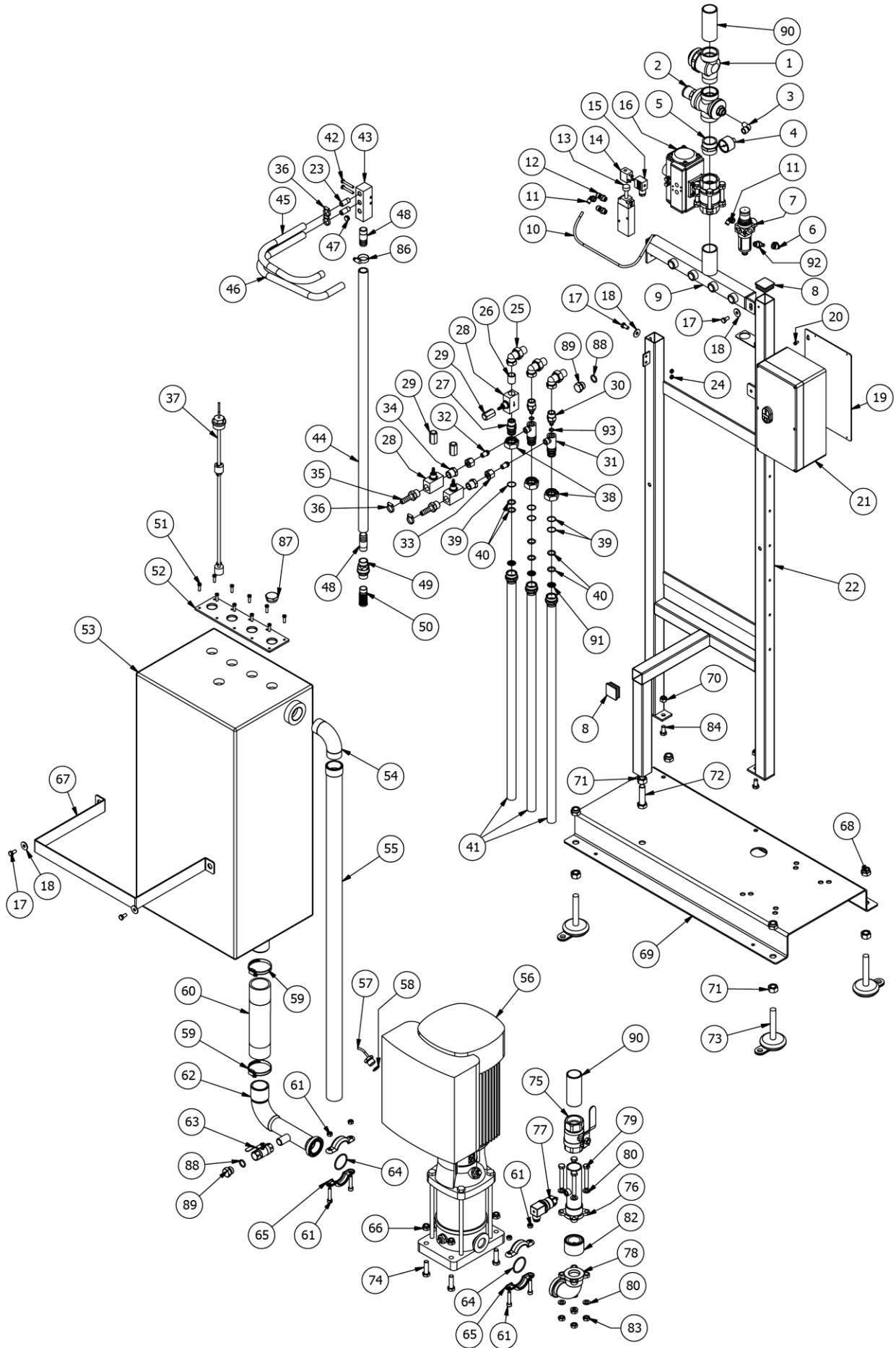

3. Parts list, KPV 100

Pos.	Part no.	Description	Material	Version
1	20-500010	Trap strainer 1.1/4" MS	Brass	All
2	19-001140	Water pressure control valve 1.1/4" MS	Nickel-plated brass	All
3	15-600061	Elbow 1/4" 90° E/I	Nickel-plated brass	All
4	22-000031	Gauge ø40 0-12 bar	AISI 304/brass/glycerine	All
5	15-100140	Hexagon nipple 1.1/4" MS	Nickel-plated brass	All
6	15-000011	Air fitting 1/4"x8 elbow	Nickel-plated brass/Plastic	All
7	20-300040	Regulator with filter	Plastic	All
8	04-000102	Plastic knob 40mm	White PP	All
9	25-330060	Inlet manifold KPE/KPV	AISI 316	All
10	55-110040	Air hose ø6mm black	PA12	All
11	15-010010	Air fitting 1/4"x6 elbow	Nickel-plated brass/Plastic	All
12	20-300070	Throttle valve 1/4"	Nickel-plated brass/Plastic	All
13	20-100130	Solenoid valve 1/4"	Nickel-plated brass	All
14	20-110131	Coil 24VAC ø10/8	Plastic/Steel	All
15	20-120031	Plug for small coil	-	All
16	20-000312	Ball valve 1.1/4" with flange and actuator	-	All
17	08-200808	Set screw M8x16	A2	All
18	08-300802	Disc washer ø8	A2	All
19	42-300010	Electrical control bracket	AISI 304	All
20	08-100505	Screw M5x10 cylinder head	A2	All
21	37-KPV100	Control KPV 100 3x400V-50Hz	-	3x400V-50Hz
21	374-KPV100	Control KPV 100 3x460V-60Hz	-	3x460V-60Hz
22	46-220030	Frame for electric control unit CP/KP 100/150	AISI 304	All
23	12-100110	Welding nipple 1/4"x30	AISI 316	All
24	08-000601	Nut M6	A2	All
25	15-600041	Elbow union 1/2"	Nickel-plated brass	All
26	15-510123	Nipple pipe 1/2"x25mm	AISI 316	All
27	16-110050	Adapter for by-pass	AISI 316	All
28	20-400030	Needle valve 1/2"	-	All
29	20-410010	Cap nut 1/2"	AISI 316	All
30	27-200160	Water nozzle ø8,0	AISI 316	All
31	27-010032	Injector housing chemical pump station	AISI 316	All
32	16-800090	Nipple for needle valve	AISI 316	All
33	16-900010	Nut 3/8"	AISI 316	All
34	15-200170	Socket 1/2"xM12X1	AISI 316	All
35	55-600080	Hose nipple 1/2"(ex)xø13,5x40	AISI 316	All
36	15-311222	Hose clip 12-22mm	A2	All
37	36-200050	Level control with float	-	All
38	27-000030	Nut M30	AISI 303	All

39	27-000020	Lock ring ø21,5x1,6	AISI 304	All
40	17-000022	O-ring 17x3	NBR	All
41	26-200060	Filling pipe for chemical pump station	AISI 316	All
42	08-200610	Set screw M6x40	A2	All
43	25-330050	Manifold for chemical pump station	AISI 316	All
44	55-200100	Suction hose ø20/27x3000mm	PVC/Steel	All
45	55-200050	Suction hose 1/2" white, m	PVC	All
46	55-200050	Suction hose 1/2" white, m	PVC	All
47	16-501401	Plug 1/4"	AISI 316	All
48	55-600130	Hose nipple 1/2"xø21x50	AISI 316	All
49	20-200092	Non-return valve 1/2"	AISI 316	All
50	27-300060	Suction filter 1/2"	AISI 316	All
51	08-100016	Tapping screw 5,5x25 PH RF	A2	All
52	44-920040	Plate for Mixing tank	AISI 304	All
53	44-900060	Mixing tank for chemical pumpstation 100/150	PE-MD	All
54	26-310010	Elbow 1.1/4"	AISI 316	All
55	26-300010	Overflow pipe KPV 100/150	AISI 316	All
56	06-000605	Pump CRNE 3-9J 4 kW	-	All
57	32-000050	Temperature switch 50° KPE	-	All
58	17-000062	O-ring 18x2	NBR	All
59	15-314060	Hose clip 40-60mm SS	A2	All
60	55-200120	Steel reinforced hose ø50/ø60	PVC/Steel	All
61	30-741010	Screw set for Flexi clamps ø48,3	A2	All
62	30-520020	Pump coupling inlet	AISI 316	All
63	20-000220	Ball valve 1/2" (blue)	AISI 316	All
64	17-030003	O-ring 46,04x3,53	Viton	All
65	30-740483	Flexi clamps ø48,3	-	All
66	08-001201	Lock nut M12	A2	All
67	44-920050	Bracket for mixing tank 100/150	AISI 304	All
68	08-001602	Lock nut M16	A2	All
69	46-220020	Pump fundation CP/KP 100/150	AISI 304	All
70	08-001002	Lock nut M10	A2	All
71	08-001601	Nut M16	A2	All
72	08-201604	Bolt M16x60 (hexagon)	A2	All
73	45-400020	Machine shoe ø80xM16 H=100mm	-	All
74	08-201207	Set screw M12x40	A2	All
75	20-000032	Ball valve 1.1/4" (blue)	-	All
76	25-200310	Outlet pipe 1.1/4"x150	AISI 316	All
77	36-100060	Pressure transmitter 0-40 bar 1/4"	-	All
78	30-510020	Pump coupling outlet	AISI 316	All
79	08-201006	Bolt M10x70 (hexagon)	A2	All

80	08-301001	Toothed disk ø10	A2	All
82	<i>20-211112</i>	<i>Non-return valve 1.1/2" PN60</i>	<i>Viton/AISI 316</i>	<i>All</i>
83	08-001001	Nut M10	A2	All
84	08-201003	Set screw M10x20 (hexagon)	A2	All
86	15-311524	Hose clip 16-25mm Norma	A2	All
87	16-503000	Blind plug M30x1,5	AISI 316	All
88	<i>17-030004</i>	<i>O-ring 17x3 70 sh</i>	<i>Viton</i>	<i>All</i>
89	16-501200	Plug 1/2"	AISI 304	All
90	15-510206	Nipple pipe 1.1/4"x100mm NPT/BSPT	AISI 304	NPT
91	54-500010	Filter ø20 mm	AISI 304	All
92	15-000010	Adapter ø8x1/4" NPT SS	AISI 304	NPT
93	<i>17-020055</i>	<i>O-ring 10x2 70 sh</i>	<i>EPDM</i>	<i>All</i>

Please note that all wearing parts appear in italics

3. Spare parts, KPV 150

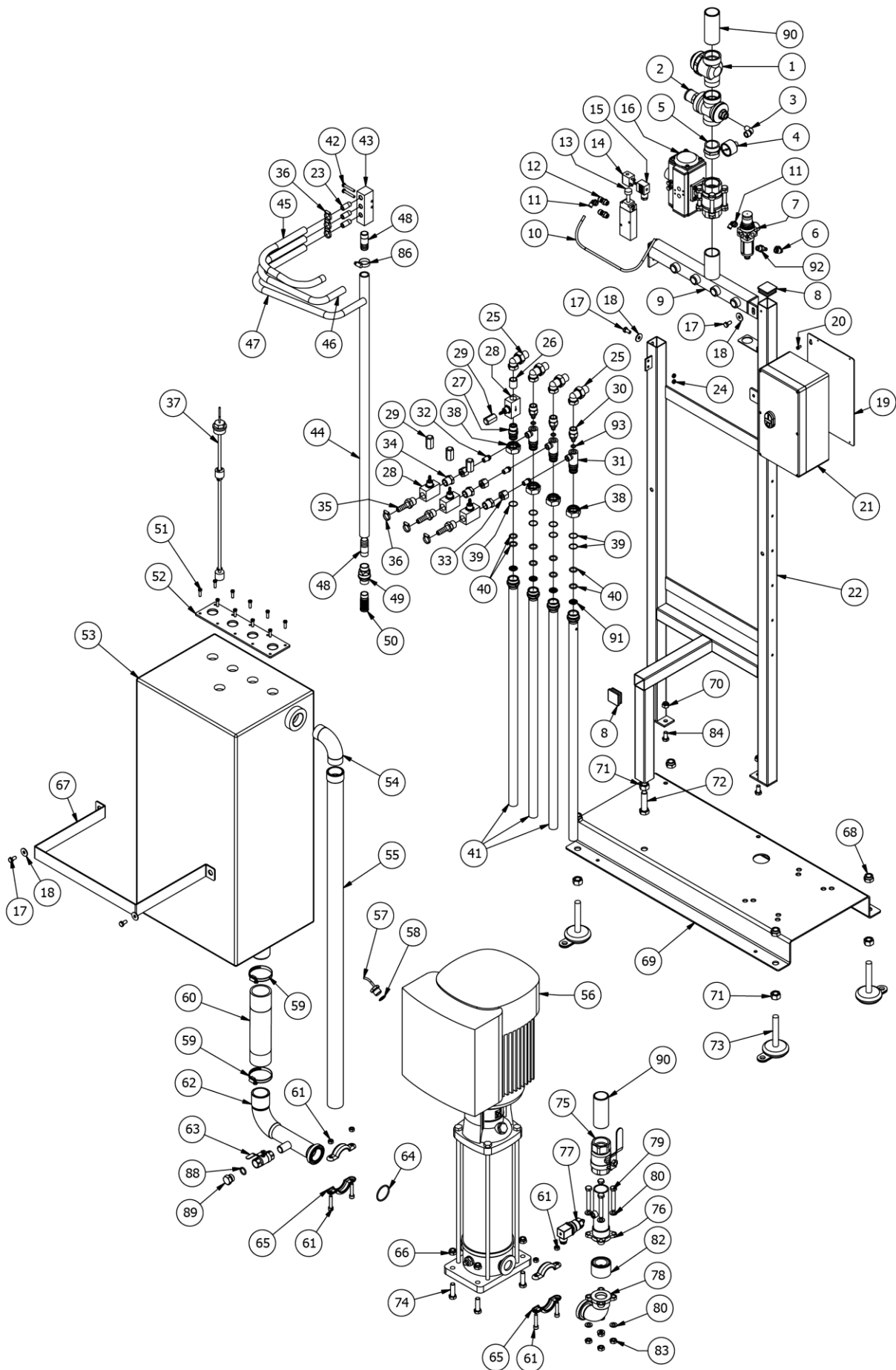

3. Parts list, KPV 150

Pos.	Part no.	Description	Material	Version
1	20-500010	Trap strainer 1.1/4" MS	Brass	All
2	19-001140	Water pressure control valve 1.1/4" MS	Nickel-plated brass	All
3	15-600061	Elbow 1/4" 90° E/I	Nickel-plated brass	All
4	22-000031	Gauge ø40 0-12 bar	AISI 304/brass/glycerine	All
5	15-100140	Hexagon nipple 1.1/4" MS	Nickel-plated brass	All
6	15-000011	Air fitting 1/4"x8 elbow	Nickel-plated brass/Plastic	All
7	20-300040	Regulator with filter	Plastic	All
8	04-000102	Plastic knob 40mm	White PP	All
9	25-330060	Inlet manifold KPE/KPV	AISI 316	All
10	55-110040	Air hose ø6mm black	PA12	All
11	15-010010	Air fitting 1/4"x6 elbow	Nickel-plated brass/Plastic	All
12	20-300070	Throttle valve 1/4"	Nickel-plated brass/Plastic	All
13	20-100130	Solenoid valve 1/4"	Nickel-plated brass	All
14	20-110131	Coil 24VAC ø10/8	Plastic/Steel	All
15	20-120031	Plug for small coil	-	All
16	20-000312	Ball valve 1.1/4" with flange and actuator	-	All
17	08-200808	Set screw M8x16	A2	All
18	08-300802	Disc washer ø8	A2	All
19	42-300010	Electrical control bracket	AISI 304	All
20	08-100505	Screw M5x10 cylinder head	A2	All
21	37-KPV150	Control KPV 150 3x400V-50Hz	-	3x400V-50Hz
21	374-KPV150	Control KPV 150 3x460V-60Hz	-	3x460V-60Hz
22	46-220030	Frame for electric control unit CP/KP 100/150	AISI 304	All
23	12-100110	Welding nipple 1/4"x30	AISI 316	All
24	08-000601	Nut M6	A2	All
25	15-600041	Elbow union 1/2"	Nickel-plated brass	All
26	15-510123	Nipple pipe 1/2"x25mm	AISI 316	All
27	16-110050	Adapter for by-pass	AISI 316	All
28	20-400030	Needle valve 1/2"	-	All
29	20-410010	Cap nut 1/2"	AISI 316	All
30	27-200160	Water nozzle ø8,0	AISI 316	All
31	27-010032	Injector housing chemical pump station	AISI 316	All
32	16-800090	Nipple for needle valve	AISI 316	All
33	16-900010	Nut 3/8"	AISI 316	All
34	15-200170	Socket 1/2"xM12X1	AISI 316	All
35	55-600080	Hose nipple 1/2"(ex)xø13,5x40	AISI 316	All
36	15-311222	Hose clip 12-22mm	A2	All
37	36-200050	Level control with float	-	All
38	27-000030	Nut M30	AISI 303	All

39	27-000020	Lock ring ø21,5x1,6	AISI 304	All
40	17-000022	O-ring 17x3	NBR	All
41	26-200060	Filling pipe for chemical pump station	AISI 316	All
42	08-200610	Set screw M6x40	A2	All
43	25-330050	Manifold for chemical pump station	AISI 316	All
44	55-200100	Suction hose ø20/27x3000mm	PVC/Steel	All
45	55-200050	Suction hose 1/2" white, m	PVC	All
46	55-200050	Suction hose 1/2" white, m	PVC	All
47	55-200050	Suction hose 1/2" white, m	PVC	All
48	55-600130	Hose nipple 1/2"xø21x50	AISI 316	All
49	20-200092	Non-return valve 1/2"	AISI 316	All
50	27-300060	Suction filter 1/2"	AISI 316	All
51	08-100016	Tapping screw 5,5x25 PH RF	A2	All
52	44-920040	Plate for Mixing tank	AISI 304	All
53	44-900060	Mixing tank for chemical pumpstation 100/150	PE-MD	All
54	26-310010	Elbow 1.1/4"	AISI 316	All
55	26-300010	Overflow pipe KPV 100/150	AISI 316	All
56	06-000510	Pump CRNE 5-14J CA-P-GI-E-HQQ	-	All
57	32-000050	Temperature switch 50° KPE	-	All
58	17-000062	O-ring 18x2	NBR	All
59	15-314060	Hose clip 40-60mm SS	A2	All
60	55-200120	Steel reinforced hose ø50/ø60	PVC/Steel	All
61	30-741010	Screw set for Flexi clamps ø48,3	A2	All
62	30-520020	Pump coupling inlet	AISI 316	All
63	20-000220	Ball valve 1/2" (blue)	AISI 316	All
64	17-030003	O-ring 46,04x3,53	Viton	All
65	30-740483	Flexi clamps ø48,3	-	All
66	08-001201	Lock nut M12	A2	All
67	44-920050	Bracket for mixing tank 100/150	AISI 304	All
68	08-001602	Lock nut M16	A2	All
69	46-220020	Pump fundation CP/KP 100/150	AISI 304	All
70	08-001002	Lock nut M10	A2	All
71	08-001601	Nut M16	A2	All
72	08-201604	Bolt M16x60 (hexagon)	A2	All
73	45-400020	Machine shoe ø80xM16 H=100mm	-	All
74	08-201207	Set screw M12x40	A2	All
75	20-000032	Ball valve 1.1/4" (blue)	-	All
76	25-200310	Outlet pipe 1.1/4"x150	AISI 316	All
77	36-100060	Pressure transmitter 0-40 bar 1/4"	-	All
78	30-510020	Pump coupling outlet	AISI 316	All
79	08-201006	Bolt M10x70 (hexagon)	A2	All

80	08-301001	Toothed disk ø10	A2	All
82	<i>20-211112</i>	<i>Non-return valve 1.1/2" PN60</i>	<i>Viton/AISI 316</i>	<i>All</i>
83	08-001001	Nut M10	A2	All
84	08-201003	Set screw M10x20 (hexagon)	A2	All
86	15-311524	Hose clip 16-25mm Norma	A2	All
88	<i>17-030004</i>	<i>O-ring 17x3 70 sh</i>	<i>Viton</i>	<i>All</i>
89	16-501200	Plug 1/2"	AISI 304	All
90	15-510206	Nipple pipe 1.1/4"x100mm NPT/BSPT	AISI 304	NPT
91	54-500010	Filter ø20 mm	AISI 304	All
92	15-000010	Adapter ø8x1/4" NPT SS	AISI 304	NPT
93	<i>17-020055</i>	<i>O-ring 10x2 70 sh</i>	<i>EPDM</i>	<i>All</i>

Please note that all wearing parts appear in italics

3. Control unit

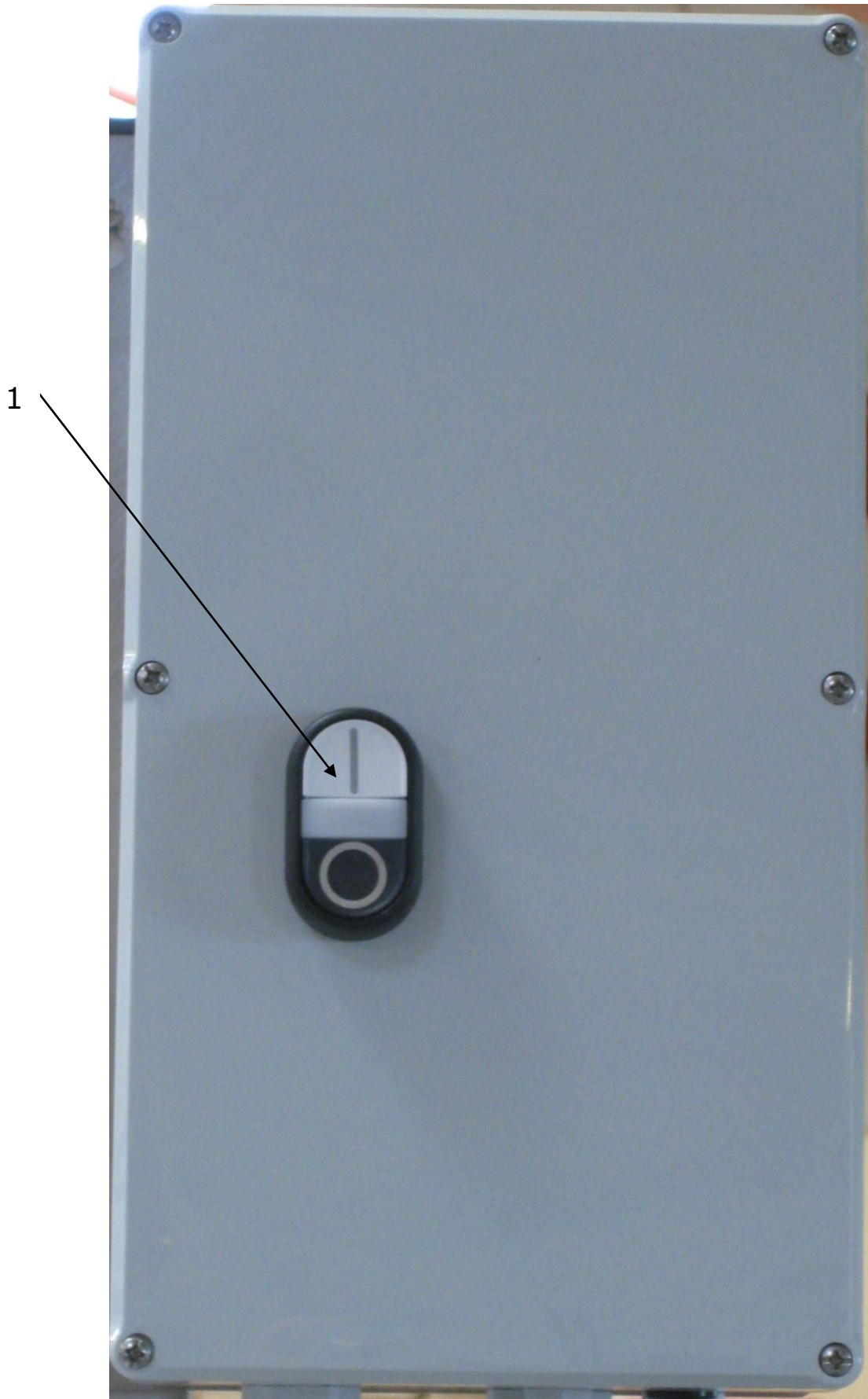

3. Control unit

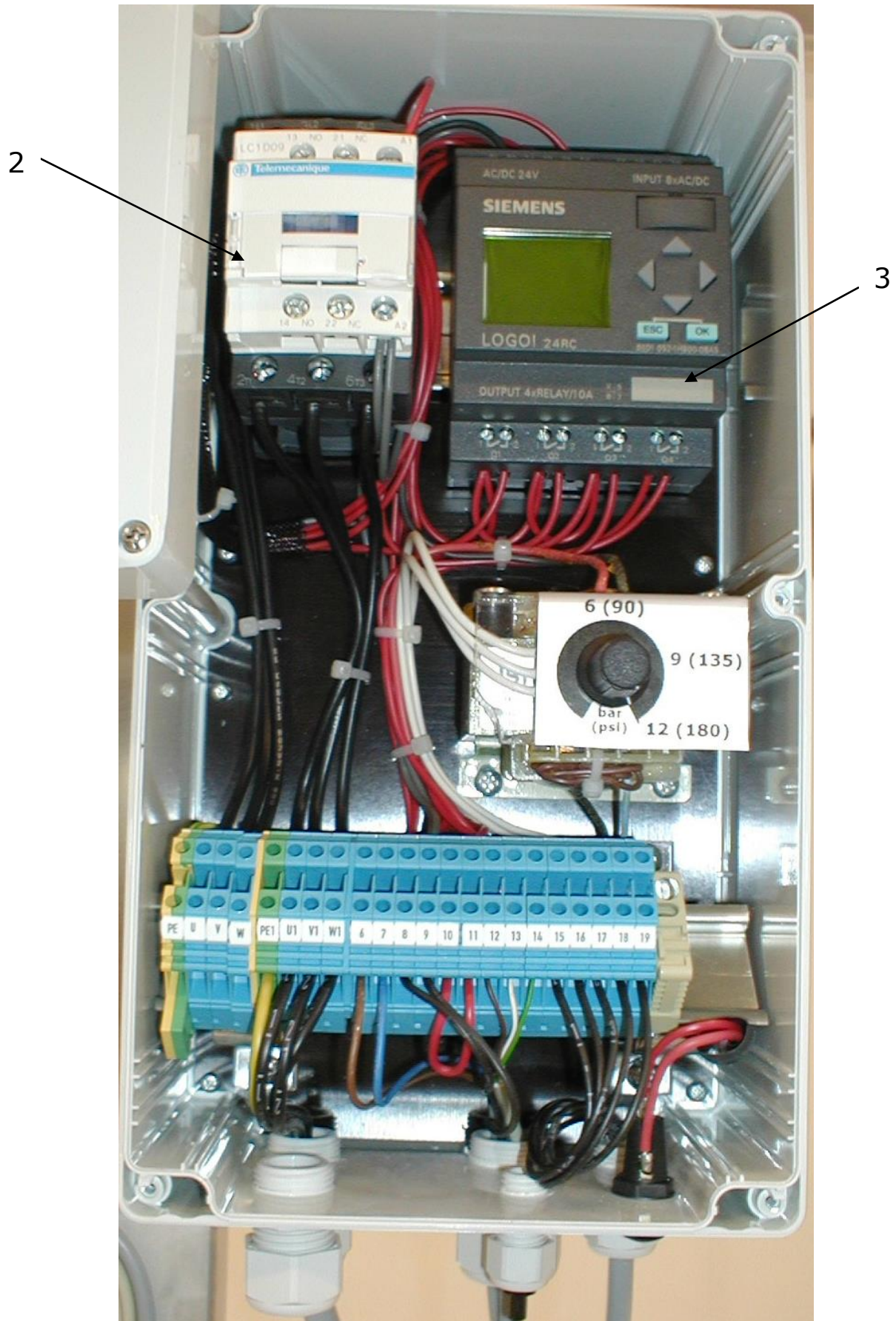

3. Control unit

Pos. no.	Part no.	Qty.	Dim.	Description	Version
1	35-300101	1	1/0	Pushbutton I/O, complete	All
2	36-600900	1	9A 24V AC	Contactator	KPV 100
2	36-601201	1	12A 24V AC	Contactator	KPV 150
3	39-LOGO	1	-	Siemens LOGO! module	All

3. Spare parts for components

Pump CRNE 3-9J and CRNE 5-14J
(best. nr. 31-309001), (best. nr. 31-309002)
(best. nr. 31-514001), (best. nr. 31-514002)

Shaft sealing cartridge
with EPDM O-rings
Part no. 32-300010

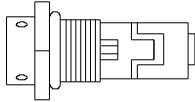

Shaft sealing cartridge
with Viton O-rings
Part no. 32-300011

Set of o-rings for pump
(with Viton O-rings)
Part no. 32-300020



1 1/4" strainer (part no. 20-500010)

Cover for 1 1/4" strainer
Part no. 20-530030

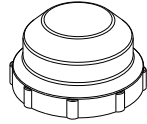

O-ring for 1 1/4" strainer
Part no. 20-520030



0.8 mm filter cartridge for 1 1/4" strai
Part no. 20-510030

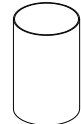

4. Quick guide



Always use safety goggles, mask and gloves.

Startup

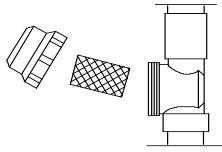

1. Clean filter

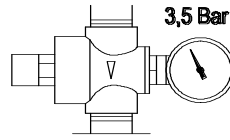

2. Set pressure to 3,5 bar

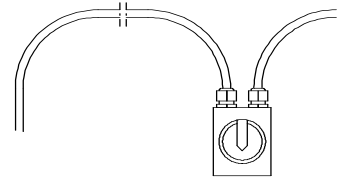

3. Connect power supply

Startup, continue

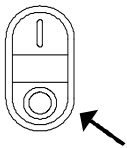

4. Press "0" until green light remains on

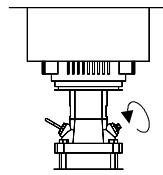

5. Open bleeder screw

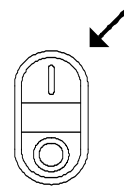

6. Press "I"

Operation

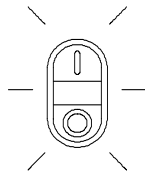

Slow flashing

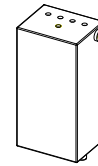

Tank is being filled, please wait.

Operation

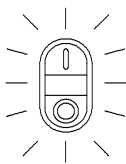

Rapid flashing

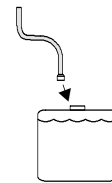

detergent

Detergent container empty - replace with new container

Operation

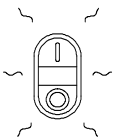

Irregular flashing container

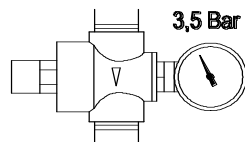

1. Check water supply

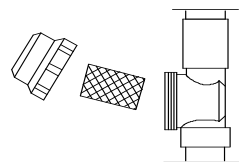

2. Clean filter

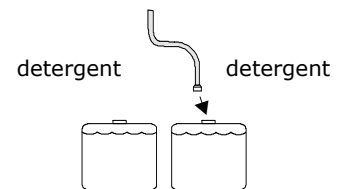

3. Replace

5. Maintenance

5.0 Strainer

The built-in water filter on the water inlet preceding the pump must be cleaned regularly, and in particular after any pipe work is carried out on the water supply in the facility. Running the system with a partly blocked filter will result in damage to the pump. It is recommended that the filter be checked at least once a year and replaced if necessary.

When cleaning the filter, close the ball valve that is fitted prior to the filter, and relieve the water pressure in the system by opening one of the outlets. Then dismantle and clean the filter.

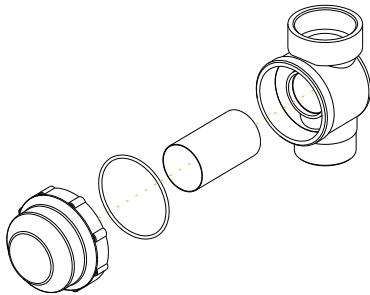

5.1 Suction filter

Clean the suction filter fitted at the end of the suction hose regularly in order to remove impurities. Check the suction filter at least twice a month and replace if necessary.

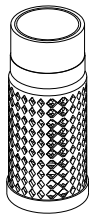

5.2 Ball valves

Tighten the spindle nuts on all ball valves regularly.

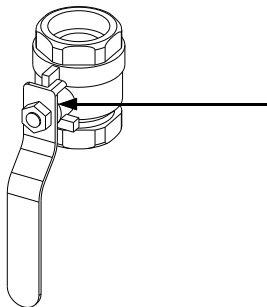

5.3 Pump

Check and tighten the pump's stay bolts regularly.

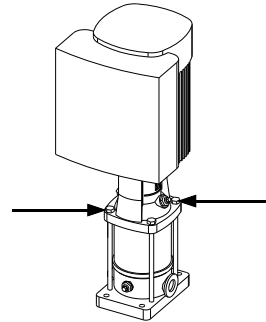

5.4 Stainless needle valve

Chemical residue can sometimes crystallize in the needle valves. It is therefore recommended that these components are inspected and cleaned every six months.

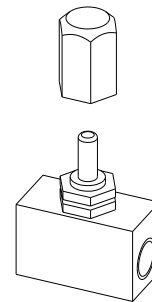

5. Maintenance, continued

5.5 Injector

Disassemble the injector system regularly - decalcify if necessary in order to prevent blockage of the injector. Clean water nozzle.

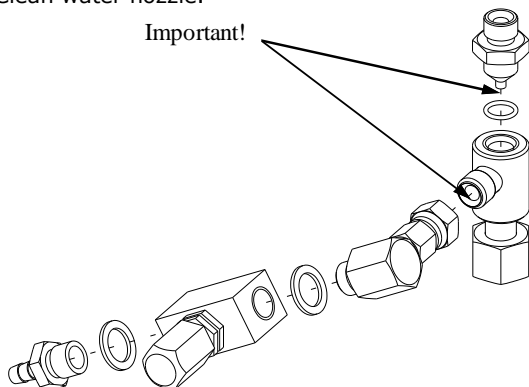

In order to ensure that the injector system does not become blocked by chemical residue, it should be flushed with clean water approx. every six months. However, there are certain types of chemicals that require the injector system to be flushed more frequently. The frequency also depends on the degree of hardness of the water.

The system is switched off by pressing "0".



Empty the mixing tank by opening the ball valve on the titration outlet. When the tank is empty, close the ball valve once more.

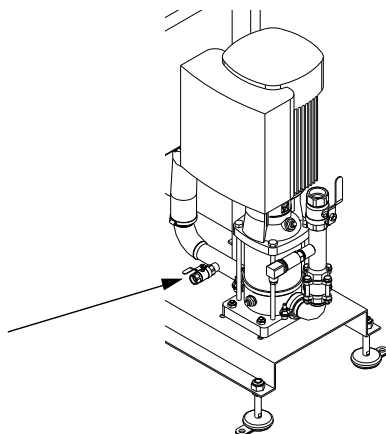

Place the suction hose in a bucket of clean water.

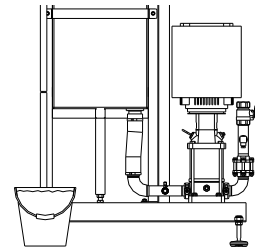

Press "0" for 15 seconds.



Then press "I".

Open the ball valve on the titration outlet and let the ball valve remain open for 2 minutes or until a continuous jet of clean water appears.

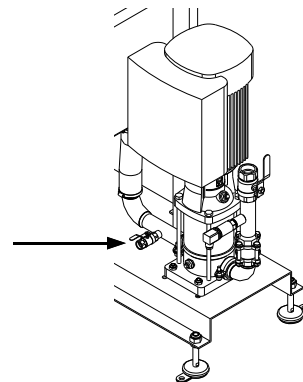

Close the ball valve on the titration outlet and switch off the system by pressing "0".



5.6 Chemical residues

"Please note that certain types of chemicals require regular flushing of the mixing tank and pump in order to prevent the build up of chemical residues on surfaces that come into contact with these chemicals. Residues of chemicals can lead to functional failures on the system. Flushing is carried out with a suitable product whilst taking into account safety and the chemical resistance of the materials in the system to the chosen product."

5. Maintenance, continued

5.7 Recommended spare parts

Part no.	Qty.	Dim.	Description	Material
<i>20-510030</i>	<i>1</i>	<i>1.1/4"</i>	<i>Filter for strainer</i>	<i>AISI 316</i>
<i>27-200160</i>	<i>2</i>	<i>ø 8.0 mm</i>	<i>Water nozzle</i>	<i>AISI 316</i>
<i>20-400030</i>	<i>3</i>	<i>1/2"</i>	<i>Needle valve</i>	<i>-</i>
<i>27-300060</i>	<i>1</i>	<i>1/2"</i>	<i>Suction filter</i>	<i>AISI 316</i>

Please note that all wearing parts appear in italics

6. Adjustment

6.1 Stainless needle valve

The chemical dosing percentage is set on the stainless steel needle valves. Screw off the cap nuts using an adjustable spanner and adjust the concentration.

The aim is to open the two needle valves to an equal extent. Fine adjustment of the chemical dosing percentage can be carried out on one of the metering valves if so required.

The valves' setting is individual and depends on the desired concentration and the viscosity of the chemical product.

Once the desired concentration has been achieved, screw the cap nuts on again.

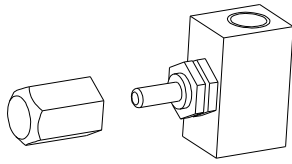

6.2 Adjusting the water pressure

The water pressure control valve's default setting provides a constant water pressure of 3.5 bar.

The water pressure can be adjusted according to local water supply conditions.

In order to obtain a constant chemical dosing percentage, it is important that the water pressure on the injectors is constant.

Water pressure should be set 0.5 bar below the lowest incoming pressure from the water utility supply.

For example, the inlet pressure fluctuates between 3.5 and 5 bar. The water pressure control valve should be set to $3.5 - 0.5 = 3$ bar.

The water pressure can be adjusted using a 5 mm Allen key when the end cover is removed from the water pressure control valve (- is lower pressure and + is higher pressure).

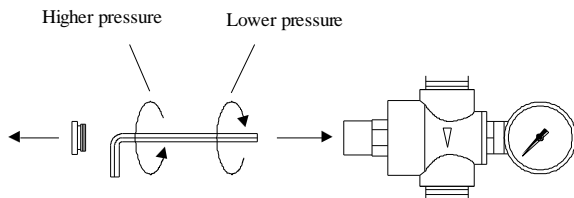

7. Troubleshooting

Fault	Cause	Remedy
Chemical pump station will not start	Supply disconnecting device interrupted.	Connect power supply to the supply disconnecting device.
	Fuse blown.	Replace the fuse.
	Thermal relay in the system's electrical cabinet cut-out. (I3 on LOGO!)	Cuts in automatically, but the cause of the cut-out should be checked by a specialist.
	Fault on power supply.	Power supply should be checked by a specialist.
	The pump has been overloaded, and as a result the water temperature has exceeded 50°C. (I3 on LOGO!)	1. Check that the timer cuts off the pump motor 3 minutes after all satellite stations on the installation have been switched off.
		2. Leaking non-return valve: The pump will run start/stop. (I7 on LOGO! goes ON shortly after the pump has stopped). Replace non-return valve.
	The system has not started.	Press "I", green operating lamp will be lit.
Chemical pump station does not stop.	Leak in pipe system	Inspect all joints.

7. Troubleshooting

Fault	Cause	Remedy
The pump runs Start/stop at short intervals.	Leak in pipe system.	Inspect all joints.
	Leaking non-return valve.	(I7 on LOGO! goes ON shortly after the pump has stopped). Replace non-return valve.
	The pump consumes more than the inlet pipe can supply. The operating lamp flashes.	Too many users, or insufficient inlet water. Clean the strainer.
No chemical flow at outlet.	Chemical pump station not started.	Start the chemical pump station by pressing button "I". The lamp will then be lit.
	Inlet and outlet valves closed.	Open the valves.
Unstable chemical flow at outlet	Pump is waiting for the level in the premixing tank, operating lamp flashes. Pressure regulator gives insufficient pressure.	Adjust the water pressure as shown in section 6.2. Check whether the water supply is adequate.
	Incorrect concentration	Set according to the chemical supplier's specifications.
	Too many users on the same chemical pump station.	See max. number of users in the technical specifications.
	Direction of rotation of pump not correct.	Change the direction of rotation as shown in the section on starting up the system.
Chemical concentration not correct.	Incorrect adjustment of metering valves.	Alter the chemical dosing percentage as described in the section on adjustment.
	External chemical container empty.	Replace/fill the chemical container.
	Suction filter above the fluid level in the chemical container.	Position the suction filter below the fluid level.
	Blocked suction filter fitted at the end of the hose for detergent.	Clean the suction filter.

8. Installation of the system

8.0 Safety instructions for mounting and installation



Important!

Never install or use damaged products. Claims concerning damage must be addressed to the carrier without delay.



Installation, commissioning and service work on System Cleaners cleaning systems may only be carried out by authorised electricians, since applicable national regulations concerning the prevention of industrial accidents (e.g. power current regulation, EN 60204, VBG 4, DIN-VDE 0100/0113/0160) must be complied with. In the event of incorrect installation, there is risk of both considerable damage to property and serious personal injury.

8.1 Location and mounting

The systems must always be located in a frost-free room.

Stationary plants must always be installed where the wall material is of solid quality and attachment carried out by means of the bolts and rawplugs supplied. Holes for the system's wall fittings should be drilled according to the dimensioned sketch. Then mount the system and secure.

8.2 Water supply



In Denmark, water connection must be carried out in accordance with "Standard for water connections" DS 439. In other countries, national standards for water connection must be followed.

If legislation in your country requires the fitting of a reverse flow locking mechanism, this must be carried out according to the local regulations.

BEFORE installing the system, flush the pipes with water in order to remove any swarf or debris from the pipes.

AFTER installing the system, flushing of the pipes must always be carried out with system set on "rinsing operation" in order to prevent dirt getting into the injector system. Flushing should be carried out until a continuous jet of clean water appears at the rinsing nozzle.

8.3 Types of pipe - pressurised water

The pipes conveying the pressurised water are produced in special galvanised pressure pipe, DIN2456/1638, stainless threaded pipe Wst.1.4301/AISI 304 or stainless dairy pipe, Wst.1.4301/AISI 304.

In order not to cause excessive pressure loss in the pipe system, it is important to produce the pipes in

recommended pipe sizes and to limit the number of elbows. In addition, please refer to the pressure loss chart.

8.4 Types of pipe - premixed detergent

It is important that only acid-resistant pipes and fittings are used.

The pipes conveying the premixed detergent are produced in acid-resistant threaded pipe, Wst:1.4404/AISI 316L or acid-resistant dairy pipe, Wst:1.4404/AISI 316L.

In the event that the piping is to be welded, this must be carried out by specialists, and a gaseous shield must always be used for all welds.

The pump in chemical pump stations develops a pressure of up to 16 bar.

On delivery of acid-resistant pipes and fittings it is essential that the DIN standard be stated.

8.5 Pressure loss chart

M ³ /h	l/min	3/4" (21,25)*	1" (27)*	1.1/4" (35,75)*	1.1/2" (41,25)*	2" (52,5)*
3,60	60	2,819 57,74	1,751 18,28	0,996 4,718	0,748 2,375	0,462 0,751

Type	3/4" (21,25)*	1" (27)*	1.1/4" (35,75)*	1.1/2" (41,25)*	2" (52,5)*
90° elbow, sliding valve	1,0	1,1	1,2	1,3	1,4
T-pieces, non-return valve	4,0	4,0	5,0	5,0	5,0

*Pipe diameter in inches and internal diameter in mm

The top figures specify the water's speed in m/sec. The bottom figures specify the pressure loss in metres Water Column per 100 m straight pipe.

The water speed should not exceed 2m/sec as this will result in noise in the pipes. Otherwise, please refer to current standards and specifications.

The table is calculated on the basis of H. Lang's current equation with $a=0.02$ and for a water temperature of 10°C.

For elbows, sliding valves, t-pieces and non-return valves, the same pressure loss can be expected as in the length (in metres) of straight pipe that is specified in the bottom table. The pressure loss for a bottom valve is assumed to be twice that of t-pieces.

8.6 Suspension of pipes

The connecting pipes for water and air must be properly suspended close to the systems so that the dead load and vibrations from the external pipe system do not have an adverse impact on the system.

8.7 Electrical installation

See separate section on "Electrical installation".

9. Key drawing, KPV 100

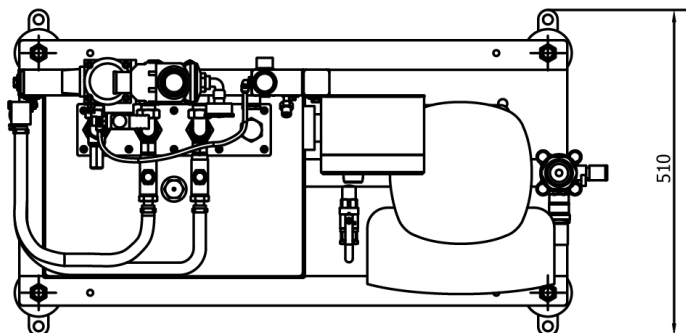
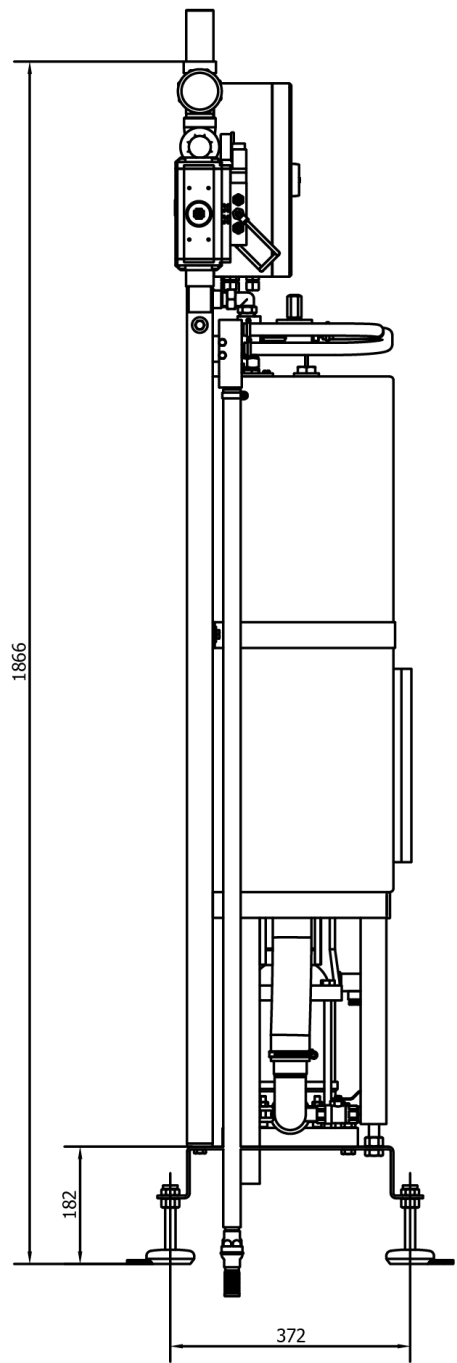
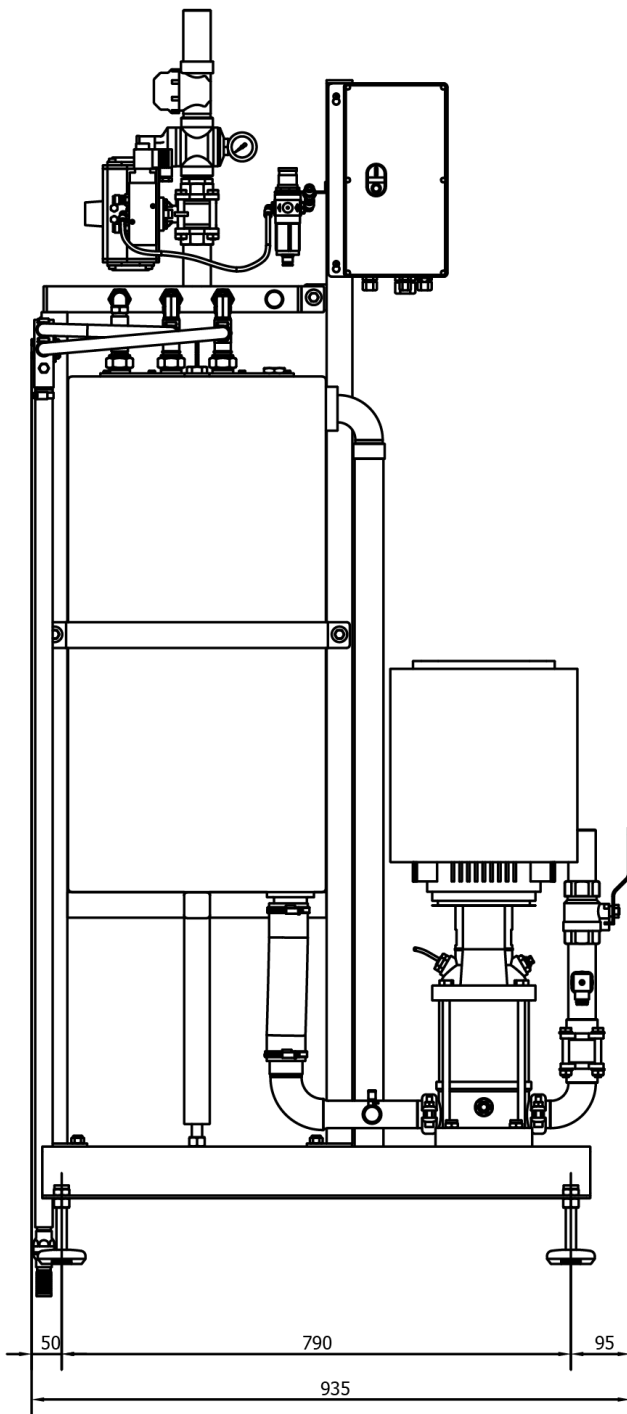

9. Key drawing, KPV 150

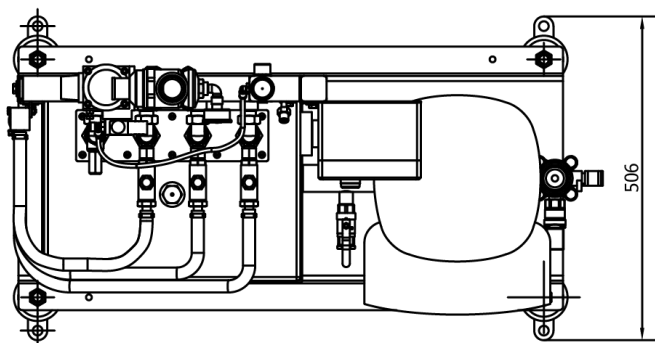
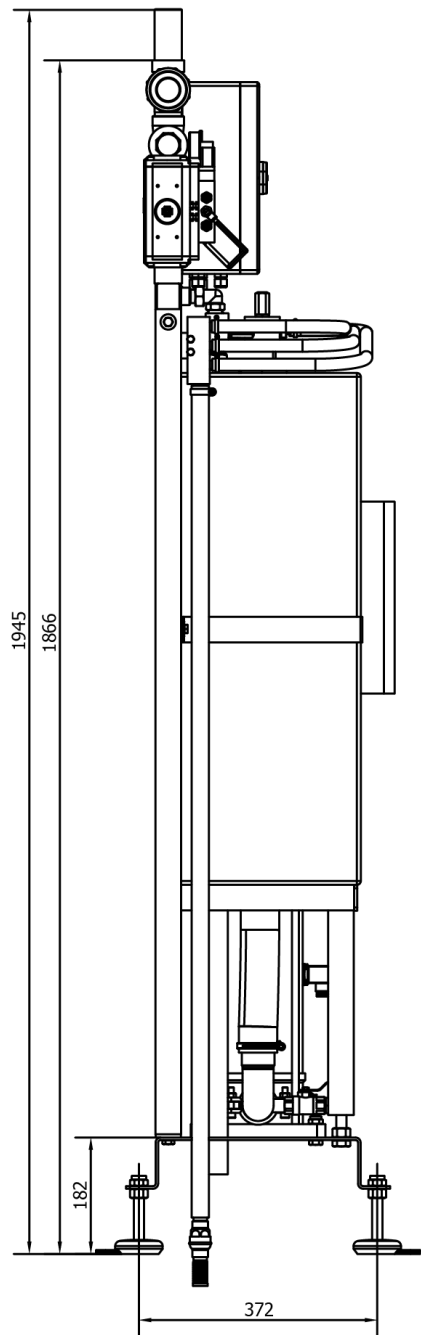
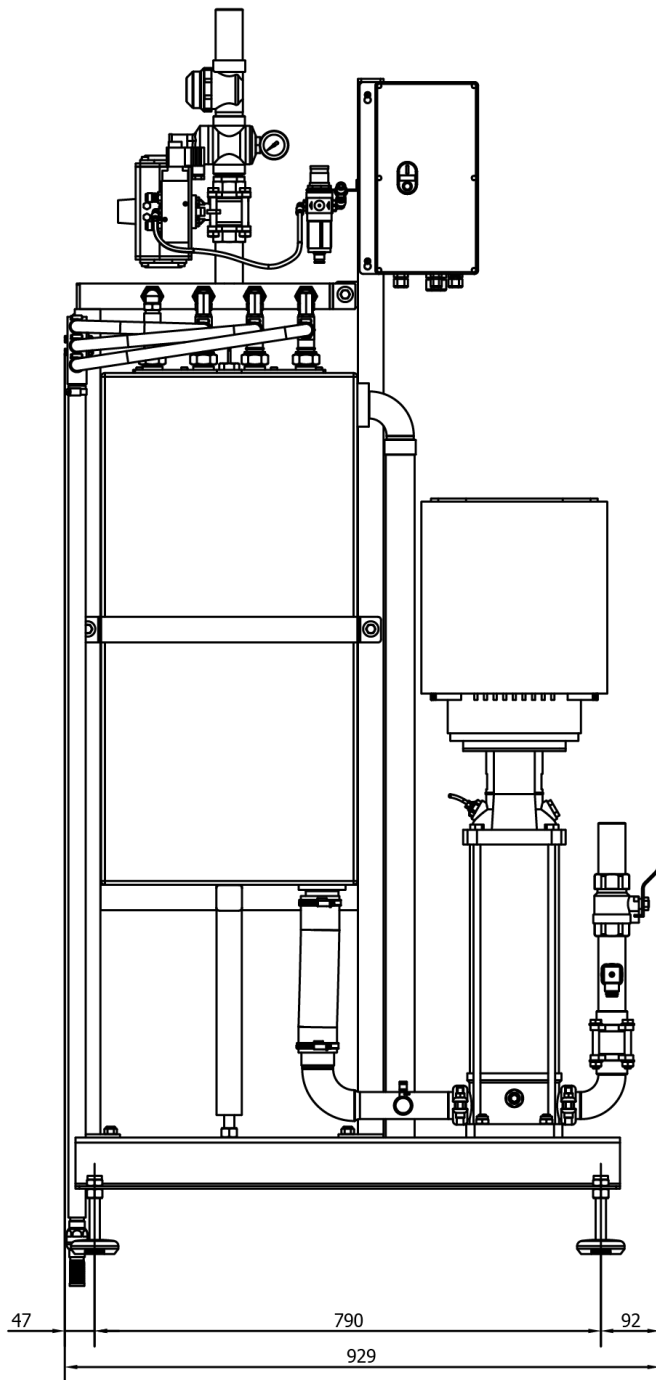

10. Starting up

10.0 Starting up after new installation or when the system's chemical tank has been emptied of fluid

Following new installation or repair of the water supply, flush the pipe system in order to remove any impurities or air pockets.

Before using the chemical pump station, clean any impurities from the filter in the strainer.

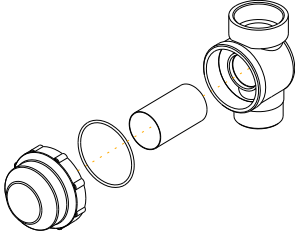

Connect the power to the chemical pump station by switching on the supply disconnecting device.

The cut-off valve, pos. l, under the integrated container must be opened. The ball valve, pos. m, must be closed.

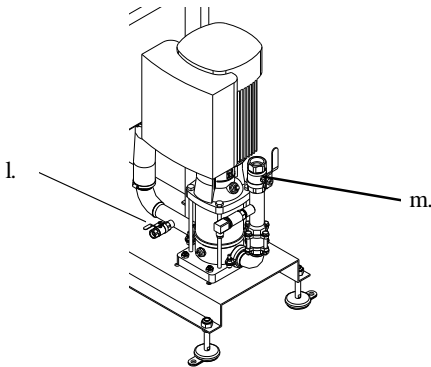

Place the suction hose with suction filter in the external chemical container and open the metering valves approx. half a turn. Before doing this the cap nuts on the metering valves must be screwed off using an adjustable spanner.

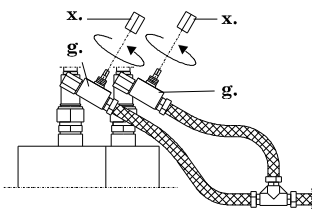

Open the bleeder screw, pos. a, on the pump a couple of turns using an adjustable spanner.

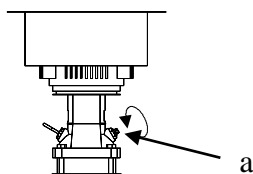

Press "0" on the start/stop switch and keep the button depressed until the fluid level in the tank has reached the upper level (approx. 15 sec.). If the button is released before the upper level is reached, filling will cease. Filling stops automatically once the upper level has been reached.

When drops of water emerge from the bleeder screw, close the screw once more.



The pump will start when "I" on the start/stop switch is activated. The indicator light will also be lit.

Fill up the pipe system for the premixed detergent by throttling the ball valve on the chemical pump station's outlet pipe. If the volume flow exceeds 50 l/min., the pump will suck the tank dry and the pump will stop whilst the tank is refilled and the green light flashes.

In order to determine the concentration, samples can be taken at the sampling point, pos. l. The concentration is determined in accordance with the chemical supplier's specifications by titration or by measuring conductivity.

If the concentration needs to be altered, this can be carried out on the two metering valves (see section on adjustment) and by adding more water via the bypass valve. Note that the concentration does not change immediately since the tank contains approx. 30 l of fluid.

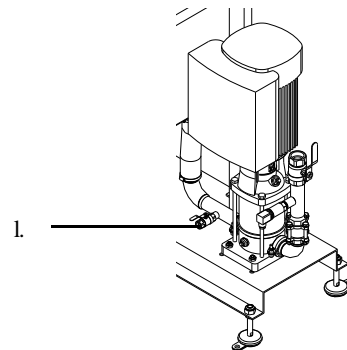

Set the water pressure control valve to 0.5 bar below the lowest incoming water pressure in order to ensure a constant chemical dosing percentage.

For example, at an inlet pressure of 4 bar, the water pressure control valve should be set to 3.5 bar.

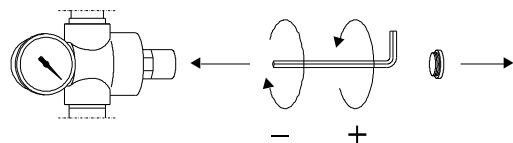

10. Starting up

10.1 Normal start

Open the ball valve on the chemical pump station.
Open the shut-off valve, pos. m.

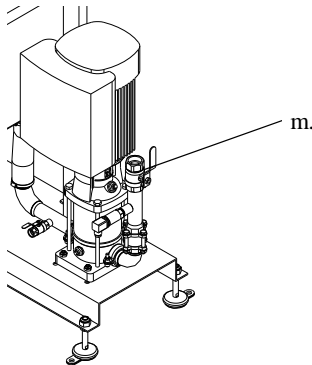

Press "I" on the start/stop switch, and the indicator light, pos. z, will come on. However, the pump will only start if the pressure in the outlet pipe is below the set pressure (set by means of the knob on the front of the control panel).

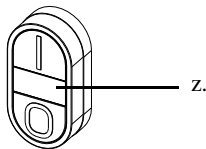

If there is no load on the system, the pump will stop automatically after about 3 minutes. The pump starts again automatically when an outlet is opened on one of the satellite stations, and the pressure thereby falls again.

The indicator light, pos. z, can also indicate faults on the system.

- Rapid regular flashing indicates a low level in the external chemical tank
- Slow regular flashing indicates low level in the internal mixing tank
- In the event of irregular flashing, both faults have occurred

10.2 Stopping the system

Switch off the system by pressing "0".



Close the ball valve, pos. m.

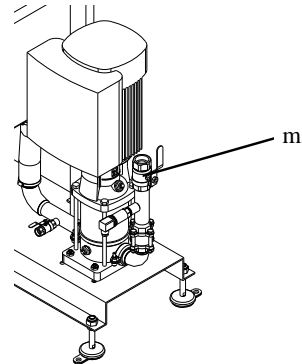

In order to ensure that the injector system does not become blocked by chemical residue, it should be flushed with clean water approx. every six months. However, there are certain types of chemicals that require the injector system to be flushed more frequently.

10.3 Adjusting the outlet pressure

The water pressure is measured at the outlet by means of a pressure transmitter situated in the pump's outlet manifold.

The measured value is compared to a set value in the frequency converter. The frequency converter regulates the speed of the motor in order to ensure that the measured value is the same as the set value.

To adjust the outlet pressure, turn the knob inside the control. The dial indicates the maximum operating pressure.

11. Electrical installation

11.1 Wiring diagram

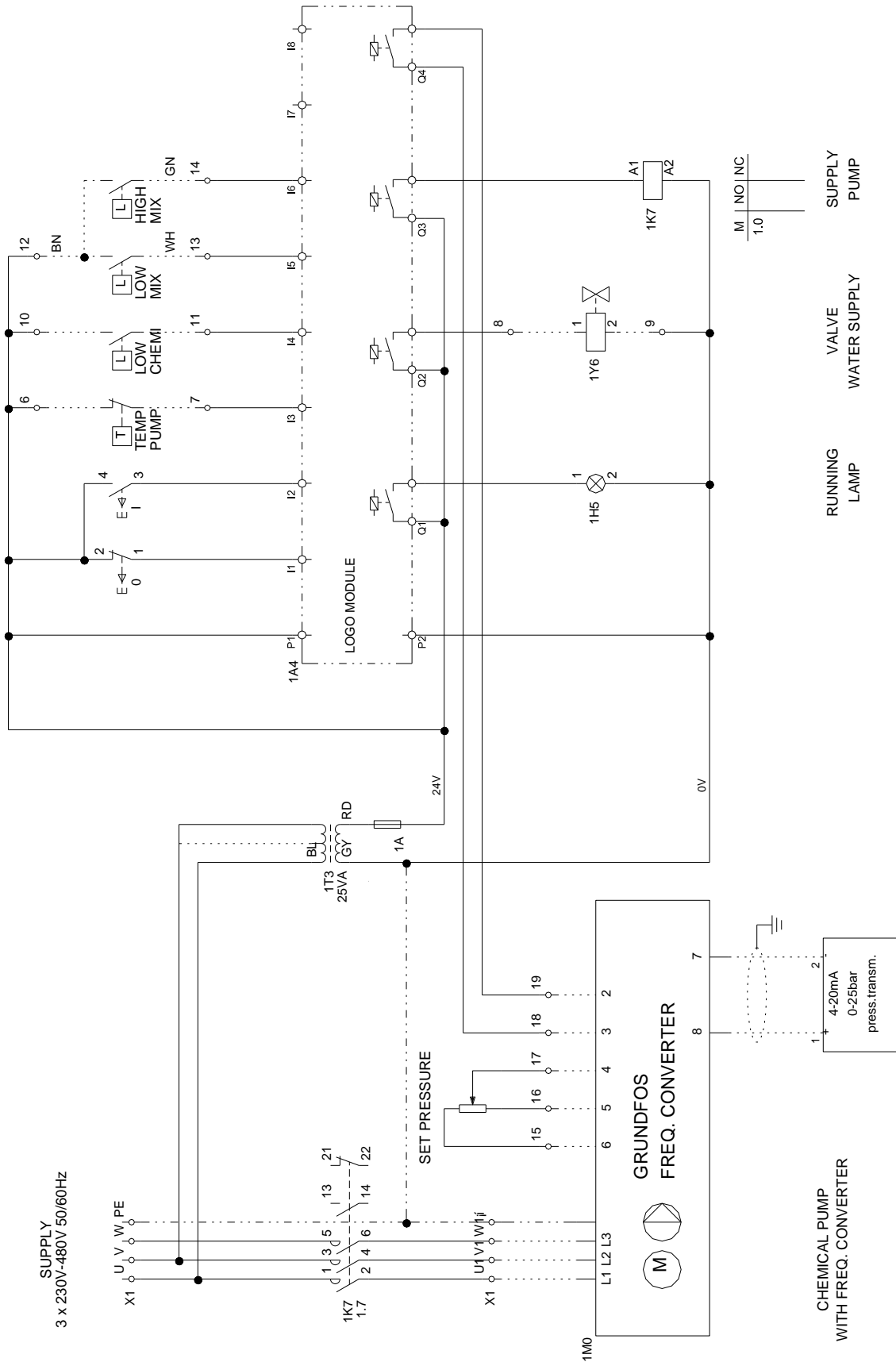

11. Electrical installation, continued

11.2 Siemens LOGO! Module

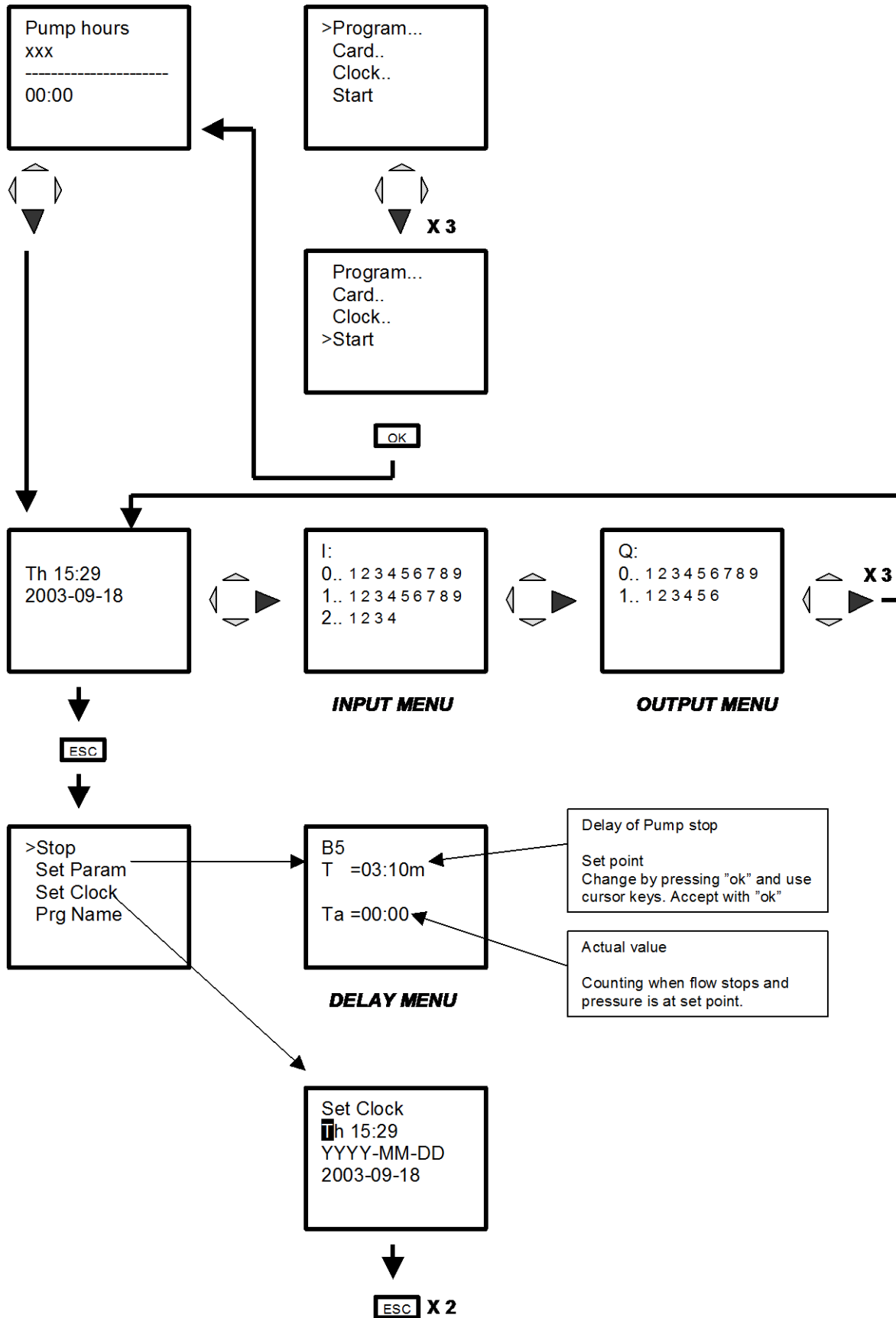

11. Electrical installation, continued

11.3 Siemens LOGO! module - Input

OFF		ON	
1	Start/stop button: "O" activated	1	Start/stop button: "O" not activated
2	Start/stop button: "I" not activated	2	Start/stop button: "I" activated
3	Temperature switch: pump temp. above 50°C Thermal relay: power consumption too high	3	Temperature switch: pump temp. below 50°C Thermal relay: Power consumption OK
4	Suction lance in chemical container: Low level	4	Suction lance in chemical container: Level OK.
5	Level switch: Level in premixing tank below minimum	5	Level switch: Level in premixing tank above minimum
6	Level switch: Level in premixing tank below maximum	6	Level switch: Level in premixing tank at maximum
7	Pressure sensitive switch: Pressure in the outlet pipe above set point	7	Pressure sensitive switch: Pressure in the outlet pipe below set point

11.4 Siemens LOGO!-modul - Output

OFF		ON	
1	Green operating lamp off	1	Green operating lamp on
2	Pilot solenoid valve (water to injector) closed	2	Pilot solenoid valve (water to injector) open
3	Grundfos pump stopped	3	Grundfos pump in operation
4	Output signal to external control unit "started and no alarm" OFF	4	Output signal to external control unit "started and no alarm" ON

12. Technical specifications

12.1 Technical specifications 3x400V-460V/50-60Hz

Model	KPV 100	KPV 150
<i>Pump:</i>		
Pump type	CRNE 3-9J	CRNE 5-14J
Power, pump, kW (HP)	4.0 (5.4)	6 (8)
Current, pump, A	7.6-6.2	11.5-9
<i>Water connection:</i>		
Pipe size	1 1/4"	1 1/4"
Min. inlet pressure, bar (psi)	3 (44)	3 (44)
Min. water supply, m ³ /h (US gal/min)	9 (40)	15 (66)
Max. temp. inlet water °C (°F)	30 (86)	30 (86)
<i>Outlet:</i>		
Pipe size	1 1/4"	1 1/4"
Flow at max. pressure, l/min (US gal/min)	106 (28.0)	177 (46.8)
Pressure (adjustable), bar (psi)	0-12 (174)	0-12 (174)
Max. number of simultaneous users at max. pressure*	15 *	25 *
<i>Metering:</i>		
Dosing percentage achievable	0.1-10% * *	0.1-10% * *
<i>Electrical connection:</i>		
Supply voltage, V	3x380-500	3x380-500
Frequency, Hz	50-60	50-60
Control voltage, V (AC)	24	24
Max. Pre-fuse, A (GG)	20	32
Cable cross section, mm ² (AWG)	4x1.5 (15)	4x2.5(13)
<i>Weight and dimensions:</i>		
Weight, kg (lbs)	110 (243)	170 (375)
Height, mm (in)	1845 (72.6)	1845 (72.6)
Width, mm (in)	954 (37.6)	965 (38)
Depth, mm (in)	512 (20.2)	512 (20.2)

* At a consumption of 7 l/min (1.8 US gal/min) per user.

** Please be aware that the concentration that can be achieved, as described in the technical specifications, is dependent on product, temperature, viscosity, density and pressure conditions. It is thus not possible to achieve 0.1-10% under all conditions.

 **SYSTEM
CLEANERS®**
System Cleaners A/S
Halkjærvej 17
DK-9200 Aalborg SV
Denmark
Tel.: +45 96 34 04 04
Fax.: +45 98 79 19 42
info@systemcleaners.com
www.systemcleaners.com

Please note:

We reserve the right to make alterations to the technical specifications without notice.